



Rift™ Caster Scooter



OWNER'S MANUAL

**Read and understand this entire manual before riding!
DO NOT RETURN TO STORE!**

**NOTE: Manual illustrations are for demonstration purposes only.
Illustrations may not reflect exact appearance of actual product.
Specifications subject to change without notice.**

**Please have your 21 character product I.D. code ready before
contacting Razor for warranty assistance and/or replacement parts.**

Product I.D. Code: _____ - _____ - _____

CONTENTS

Safety Warnings	1	Caster Scooter Parts List	5
Before You Begin.....	2	Safety Reminders.....	7
Set Up and Usage Instructions	3	Warranty	7
Check Before Riding.....	4		

SAFETY WARNINGS

⚠ AN IMPORTANT MESSAGE TO PARENTS: This manual contains important information. For your child's safety, it is your responsibility to review this information with your child and make sure that your child understands all warnings, cautions, instructions and safety topics. Razor USA recommends that you periodically review and reinforce the information in this manual with younger riders and that you are required to inspect and maintain your child's caster scooter to insure their safety.

⚠ WARNING: Caster scooter riding can be a hazardous activity. Caster scooters can and are intended to move and it is therefore possible to get into dangerous situations and/or lose control and/or fall. If such things occur you can be seriously injured or die. **LIKE ANY OTHER MOVING PRODUCT, USING A CASTER SCOOTER CAN BE A DANGEROUS ACTIVITY AND MAY RESULT IN INJURY OR DEATH EVEN WHEN USED WITH PROPER SAFETY PRECAUTIONS. USE AT YOUR OWN RISK AND USE COMMON SENSE.**

- Always wear safety equipment, such as a helmet, knee pads and elbow pads. Always wear a helmet when riding your caster scooter and keep the chinstrap securely buckled.
- The skill required to ride this product may be greater than that required to ride a traditional kick scooter.
- Do not allow children under age eight (8) to use the caster scooter. All children and preteens should ride with adult supervision at all times.
- Rider weight does not necessarily mean a child's size is appropriate to fit or maintain control of the caster scooter.
- A parent's decision to allow his or her child to ride this product should be based on the child's maturity, skill and ability to follow rules.
- Always wear closed toe shoes.
- Ride on smooth, paved surfaces away from motor vehicles.
- Avoid sharp bumps, drainage grates and sudden surface changes. Caster scooter may suddenly stop.
- Avoid streets and surfaces with water, sand, gravel, dirt, leaves and other debris. Wet weather impairs traction and visibility.
- Do not ride at night.
- Avoid excessive speed associated with downhill rides.
- Obey all local traffic and scootering laws and regulations.
- Watch out for pedestrians.
- Do not exceed 143 lb (65 kg) total weight on the caster scooter.
- Adult assembly required.

ACCEPTABLE RIDING PRACTICES AND CONDITIONS

Direct parental supervision is required. Caster scooters are meant to be used only in controlled environments, free of potential traffic hazards, and not on public streets. Do not allow your child to ride the caster scooter in any areas where vehicle traffic is present. The child must maintain a hold on the handlebars at all times. Never allow more than one child at a time to ride a caster scooter. Never use near steps, sloped driveways, hills, roadways, alleys or swimming pool areas.

Do not ride a caster scooter in wet weather. Caster scooters are intended for use on solid, flat, clean and dry surfaces, such as pavement or level ground, without loose debris, such as rocks or gravel. Wet, slick or uneven and rough surfaces may impair traction and contribute to possible accidents. Do not ride a caster scooter in mud, ice, puddles or water. Avoid excessive speeds that can be associated with downhill rides. Never risk damaging surfaces, such as carpet or flooring, by use of a caster scooter indoors. Do not ride at night or when visibility is impaired.

PROPER RIDING ATTIRE

Always ensure child is wearing proper protective equipment, such as an approved safety helmet. A helmet may be legally required by local law or regulation in your area. A child should always wear shoes, never ride barefooted or in sandals and should keep shoelaces tied and out of the way of the wheels.

FAILURE TO USE COMMON SENSE AND HEED THE ABOVE WARNINGS FURTHER INCREASES RISK OF SERIOUS INJURY. USE AT YOUR OWN RISK AND WITH APPROPRIATE AND SERIOUS ATTENTION TO SAFE OPERATION. USE CAUTION.

⚠ WARNING: ALWAYS INSPECT THE CASTER SCOOTER PRIOR TO RIDING. Properly inspecting and maintaining your caster scooter can reduce the risk of injury. Always inspect your caster scooter before riding and regularly maintain it.

⚠ WARNING: CHECK LOCAL LAWS REGARDING CASTER SCOOTER USE. Check local laws and regulations to see where and how you may use your Razor caster scooter legally. In many states and local areas, caster scooter riders are required BY LAW to wear a helmet. Check local laws and regulations regarding laws governing helmet use and caster scooter operation in your area.

BEFORE YOU BEGIN

Remove contents from box. Remove the separators that protect the components from damage during shipping. Inspect the contents of the box for scratches in the paint and dents that may have occurred during shipping. Because your caster scooter was partially assembled and packed at the factory, there should not be any problems, even if the box has a few scars or dents.

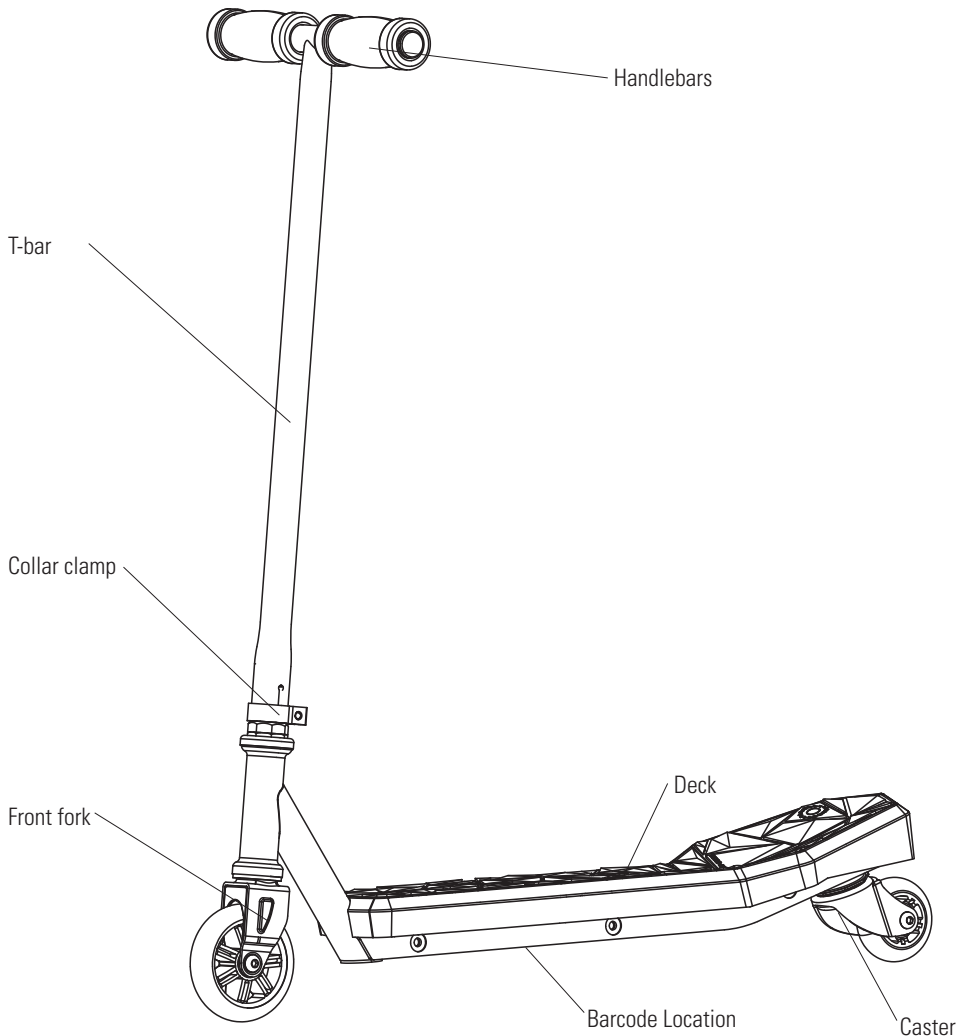

⚠ WARNING: DO NOT USE NON-RAZOR PRODUCTS WITH YOUR CASTER SCOOTER.

The Razor Rift™ caster scooter has been built to certain Razor design specifications. The original equipment supplied at the time of sale was selected on the basis of its compatibility with the frame, fork and all other parts. Certain aftermarket products may not be compatible. Use of any non-Razor parts will void your warranty.

PRODUCT I.D. CODE

1. Bottom of Frame
2. UPC Side of Box (not shown)

□ Required Tools

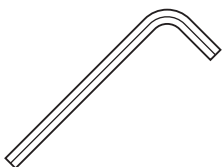

5mm Allen wrench
(included)

Need Help? Visit our web site for replacement parts, product support and a list of authorized service centers at www.razor.com or call toll free 866-467-2967 Monday - Friday 8AM - 5PM Pacific Time. Please have the product I.D. code (located on the bottom of the frame) available for better assistance.

SET UP AND USAGE INSTRUCTIONS

□ Installing the T-bar

Required Tools: 5 mm Allen wrench



1 Using a 5 mm Allen wrench, loosen the collar clamp and slide it upward. With a clockwise twisting motion, push and “thread” the T-bar onto the fork until it bottoms out on the fork headset lock nut.

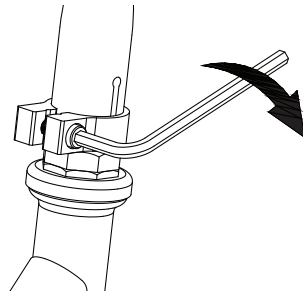

2 With the front wheel pointed straight ahead and the handlebars square to the front wheel, tighten the clamp as shown. Tighten securely.

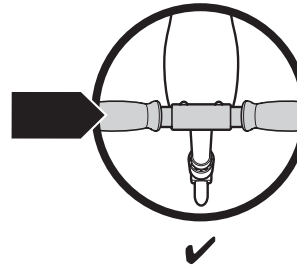
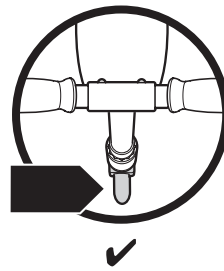

⚠ WARNING: Failure to properly install and tighten the collar clamp may cause the rider to lose control and fall. If you do not understand these instructions, please contact Razor Customer Care for assistance.

CHECK BEFORE RIDING

❑ Collar Clamp

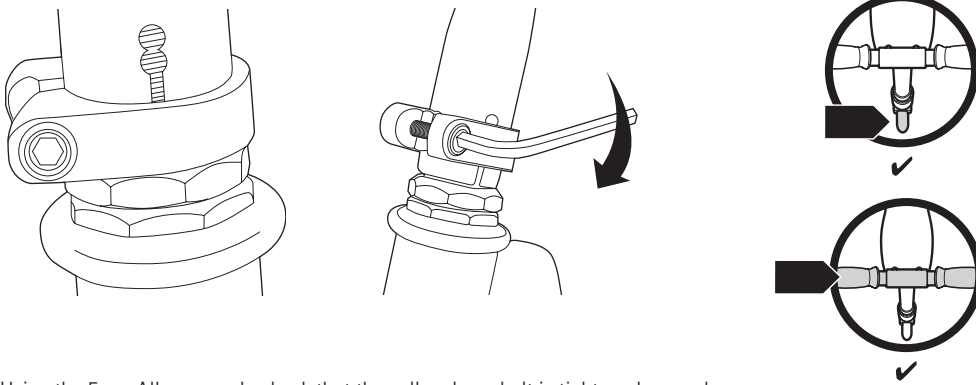

Using the 5mm Allen wrench, check that the collar clamp bolt is tightened securely.

Note: If the handlebars are not properly aligned with the front wheel, loosen the bolt on the collar clamp and position the front wheel until it is perpendicular with the steering tube; retighten bolt on collar clamp to lock in place.

❑ Wheels and Bearings

Under normal circumstances and conditions, Razor wheels and wheel bearings are maintenance free. Nonetheless, it is the responsibility of the owner or guardian to periodically inspect the wheels for wear and tear, the axle for proper tightness, and the bearings for side-to-side play and loose parts. When a wheel or wheel bearing develops play, this is an indication of excess wear and replacement is necessary. Replace immediately with only genuine Razor wheels. Worn wheels and bearings are considered normal wear-and-tear and are not covered by the Razor Warranty. Wheels other than genuine Razor wheels may not be compatible with your Rift™ caster scooter. The use of anything other than genuine Razor replacement parts may affect your safety and will void your warranty.

❑ Cleaning Your Caster Scooter

Wipe with a damp cloth to remove dirt and dust. Do not use industrial cleaners or solvents, as they may damage the surfaces. Do not use alcohol, alcohol-based or ammonia-based cleaners, as they may damage or dissolve the plastic components or soften the decals or decal adhesive.

❑ How to Ride

Place both hands firmly on the handlebars and hold the caster scooter in the upright position. Place one foot securely on the deck and the other foot on the ground for stability. When you are ready, carefully push off to begin the rolling action. Once in motion, the caster scooter can be ridden like any other kick scooter and because of its unique design, you can gain and maintain speed by swinging the back end in a back and forth “fishtail” motion. The caster scooter also allows you to carve/drift turns by adjusting the angle of your body from side to side. To learn all the different ways you can maneuver the caster scooter, Razor recommends you practice in a safe area free from obstructions before riding around others.

⚠ WARNING: Wheelies and other stunt-type riding reduces your ability to maneuver and control your caster scooter. Take the necessary precautions, such as wearing appropriate protective gear, and practice in an area free from obstructions.

Need Help? Visit our web site for replacement parts, product support and a list of authorized service centers at www.razor.com or call toll free 866-467-2967 Monday - Friday 8AM - 5PM Pacific Time. Please have the product I.D. code (located on the bottom of the frame) available for better assistance.

CASTER SCOOTER PARTS LIST

Keep your caster scooter working for years with genuine Razor parts. Visit our web site or e-mail us for more information on spare part availability. (Specifications subject to change without notice.)

- | | |
|-----------------------------------|----------------------------|
| 1. Handlebar Grips | 6. Axle Bolts (front/rear) |
| 2. T-Bar | 7. Front Wheel |
| 3. Collar Clamp | 8. Deck |
| 4. Headset Bearings (upper/lower) | 9. Rear Caster |
| 5. Front Fork | 10. Rear Wheel |
| 5-1. Fork Protector | |

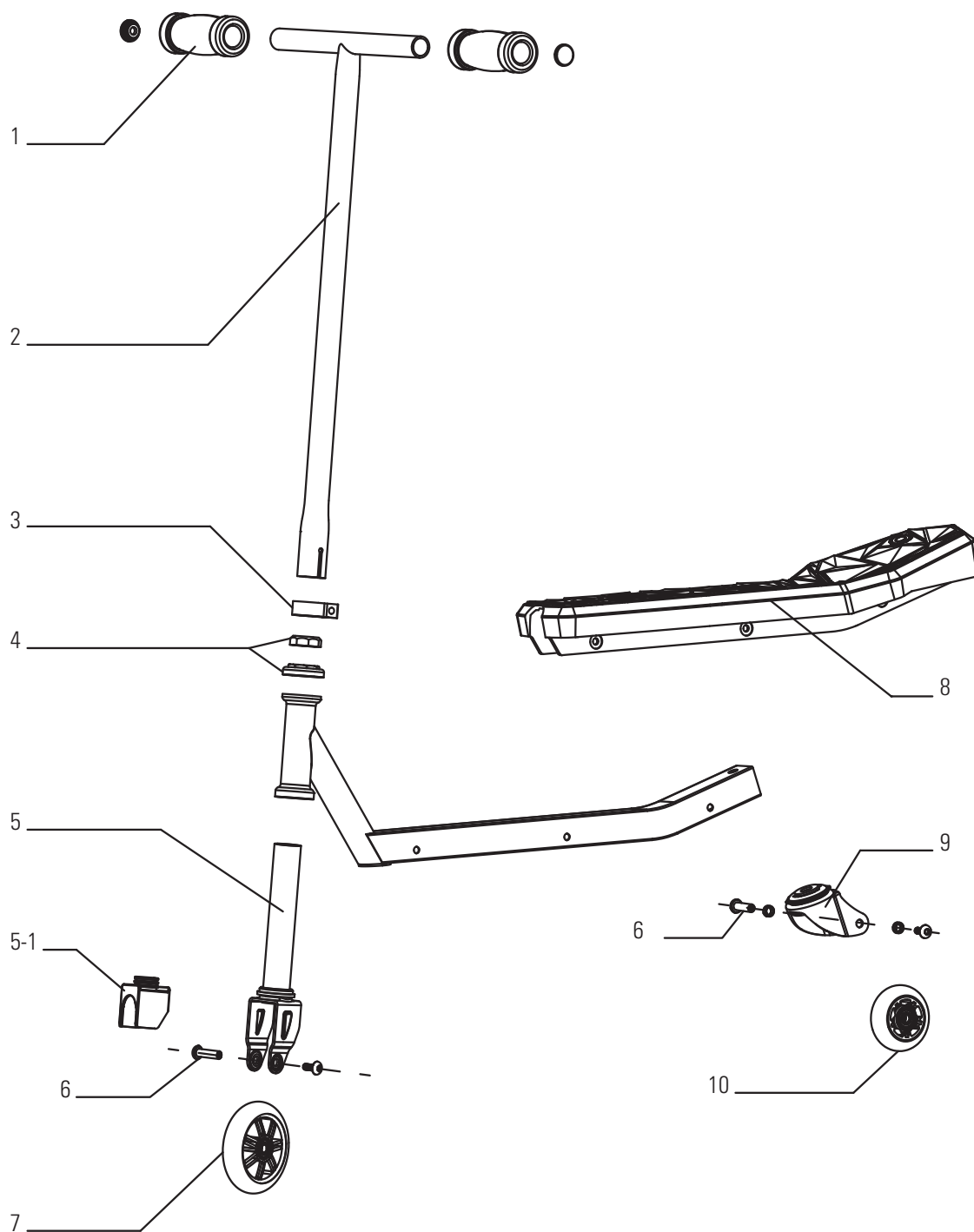

SAFETY REMINDERS

PRE-RIDE CHECKLIST



Loose Parts

Check and secure all fasteners before every ride. Make sure the collar clamp is locked properly in place before riding.



Replacement Parts

For a complete selection of parts, visit our website at www.razor.com.



Safety Gear

Always wear proper protective equipment, such as an approved safety helmet. Elbow pads and kneepads are recommended.

Always wear shoes (lace-up shoes with rubber soles), never ride barefooted or in sandals, and keep shoelaces tied and out of the way of the wheels.



Be Careful!

You will see people on TV and maybe even people you know doing tricks and stunts. These are people who have been practicing on scooters for a very long time. Don't try something until you are ready. Avoid steep inclines and don't ride too fast — you can lose control and fall. Skateboard parks are not designed for caster scooters. Never ride in traffic or on the street, and watch your surroundings for pedestrians, bikers, boarders, scooter riders and skaters.

Maintain a hold on the handlebars at all times.



DO NOT RETURN TO STORE

Failure to follow these instructions may damage your caster scooter and void your warranty.

WARRANTY

Razor Limited Warranty

The manufacturer warrants this product to be free of manufacturing defects for a period of 6 months from date of purchase. This Limited Warranty does not cover normal wear and tear of wheels and bearings or any damage, failure or loss caused by improper maintenance or storage.

This Limited Warranty will be void if the product is ever:

- used in a manner other than for recreation;
- modified in any way;
- rented.

The manufacturer is not liable for incidental or consequential loss or damage due directly or indirectly to the use of this product.

Razor does not offer an extended warranty. If you have purchased an extended warranty, it must be honored by the store at which it was purchased.

Need Help? Visit our web site for replacement parts, product support and a list of authorized service centers at www.razor.com or call toll free 866-467-2967 Monday - Friday 8AM - 5PM Pacific Time. Please have the product I.D. code (located on the bottom of the frame) available for better assistance.

Printed in China for:
Razor USA LLC
P.O. Box 3610
Cerritos, CA 90703

Copyright © 2003-2013 Razor USA LLC. All rights reserved. RAZOR and the Razor Logo Design are among the registered trademarks of Razor USA LLC in the United States and/or select foreign countries. Rift is a trademark of Razor USA.

For your records, save your original sales receipt with this manual and write the serial number below.
