



KID-POWERED DRIFTING GO-CART



OWNER'S MANUAL

Read and understand this entire manual before allowing child to use this product!

NOTE: Manual illustrations are for demonstration purposes only. Illustrations may not reflect exact appearance of actual product. Specifications subject to change without notice.

Please have your product along with the 22 character product I.D. code with you before contacting for replacement parts.

Product I.D. Code: _____ - _____ - _____

CONTENTS

Safety Warnings.....	1	Usage.....	6-7
Before You Begin.....	2	Product Parts.....	8
Assembly and Set-Up.....	3-5		
Pre-Ride Checklist.....	6		

SAFETY WARNINGS

⚠ WARNING: Riding the Crazy Cart Shuffle™ can be a hazardous activity. Certain conditions may cause the equipment to fail without fault of the manufacturer. The Crazy Cart Shuffle can and is intended to move, and it is therefore possible to lose control, fall off and/or get into dangerous situations that no amount of care, instruction or expertise can eliminate. If such things occur you can be seriously injured or die, even when using safety equipment and other precautions. **RIDE AT YOUR OWN RISK AND USE COMMON SENSE.**

⚠ AN IMPORTANT MESSAGE TO PARENTS: This manual contains many warnings and cautions concerning the consequences of failing to maintain, inspect or properly use your Crazy Cart Shuffle. Because any incident can result in serious injury or even death, we do not repeat the warning of potential serious injury or death each time such a possibility is mentioned.

APPROPRIATE RIDER USE AND PARENTAL SUPERVISION

Direct adult supervision is required at all times. This manual contains important safety information. It is a parent or supervising adult's responsibility to review this information and make sure that all riders understand all warnings, cautions, instructions and safety topics, and assure that young riders are able to safely and responsibly use this product. Razor recommends that you periodically review and reinforce the information in this manual with younger riders, and that you inspect and maintain your child's Crazy Cart Shuffle to ensure their safety.

The recommended rider age of 4 and older for Crazy Cart Shuffle is only an estimate, and can be affected by the rider's size, weight or skills. Any rider unable to fit comfortably on the Crazy Cart Shuffle should not attempt to ride it. **A parent's decision to allow his or her child to ride this product should be based on the child's maturity, skill and ability to follow rules.**

Keep this product away from small children, and remember that this product is intended for use only by persons who are, at a minimum, completely comfortable and competent while operating the Crazy Cart Shuffle.

DO NOT EXCEED THE WEIGHT LIMIT OF 150 lb (68 KG).

Rider weight does not necessarily mean a person's size is appropriate to fit or maintain control of the Crazy Cart Shuffle.

ACCEPTABLE RIDING PRACTICES AND CONDITIONS

Direct parental supervision is required. Always check and obey any local laws or regulations which may affect the locations where the Crazy Cart Shuffle may be used on public property. The Crazy Cart Shuffle is meant to be used only in controlled environments free of potential traffic hazards and not on public streets. Do not ride your Crazy Cart Shuffle in any areas where pedestrian or vehicle traffic is present.

Ride defensively. Watch out for potential obstacles that could force you to swerve suddenly or lose control. Be careful to avoid pedestrians, skaters, skateboards, scooters, bikes, children or animals who may enter your path, and respect the rights and property of others.

Maintain a hold on the drift bars at all times.

Never carry passengers or allow more than one person at a time to ride the Crazy Cart Shuffle.

Never use near streets, swimming pools, hills, steps, roadways, alleys, or sloped driveways.

Never use headphones, a cell phone or text when riding.

Never hitch a ride with a vehicle.

Do not ride the Crazy Cart Shuffle in wet weather. The Crazy Cart Shuffle is intended for use on solid, flat, clean and dry surfaces, such as pavement or level ground, without loose debris, such as rocks or gravel. Wet, slick or uneven and rough surfaces may impair traction and contribute to possible accidents. Do not ride the Crazy Cart Shuffle in mud, ice, puddles or water. Avoid excessive speeds that can be associated with downhill rides. Never risk damaging surfaces, such as carpet or flooring, by use of a Crazy Cart Shuffle indoors.

Do not ride at night or when visibility is impaired.

This product has no brake. Place feet on floor to stop.

Only ride Crazy Cart Shuffle while seated.

Never attempt to mount or dismount product while it is moving.

PROPER RIDING ATTIRE

Always wear proper protective equipment, such as an approved safety helmet (with chin strap securely buckled). A helmet may be legally required by local law or regulation in your area. Elbow and kneepads, long sleeved shirt and long pants are recommended. Always wear closed toe shoes, and keep shoelaces tied and out of the way of the wheels. Never ride barefooted or in sandals.

⚠ WARNING: ALWAYS INSPECT CRAZY CART SHUFFLE PRIOR TO RIDING. Properly inspecting and maintaining your Crazy Cart Shuffle can reduce the risk of injury. Always inspect your Crazy Cart Shuffle before riding and regularly maintain it.

⚠ WARNING: CHECK LOCAL LAWS REGARDING CRAZY CART SHUFFLE USE. Check local laws and regulations to see where and how you may use your Razor Crazy Cart Shuffle legally. In many states and local areas, Crazy Cart Shuffle riders may be required BY LAW to wear a helmet. Check local laws and regulations regarding laws governing helmet use and Crazy Cart Shuffle operation in your area.

FAILURE TO USE COMMON SENSE AND HEED THE ABOVE WARNINGS INCREASES RISK OF SERIOUS INJURY. USE WITH APPROPRIATE CAUTION AND SERIOUS ATTENTION TO SAFE OPERATION.

BEFORE YOU BEGIN

Remove contents from box and check parts against diagram below. Remove the separators that protect the components from damage during shipping. Inspect the contents of the box for scratches in the paint or dents that may have occurred during shipping. Because the Crazy Cart Shuffle was partially assembled and packed at the factory there should not be any problems, even if the box has a few scars or dents.

Estimated Assembly and Set-Up Time

Allow up to 15–20 minutes for assembly. Razor recommends assembly by an adult.

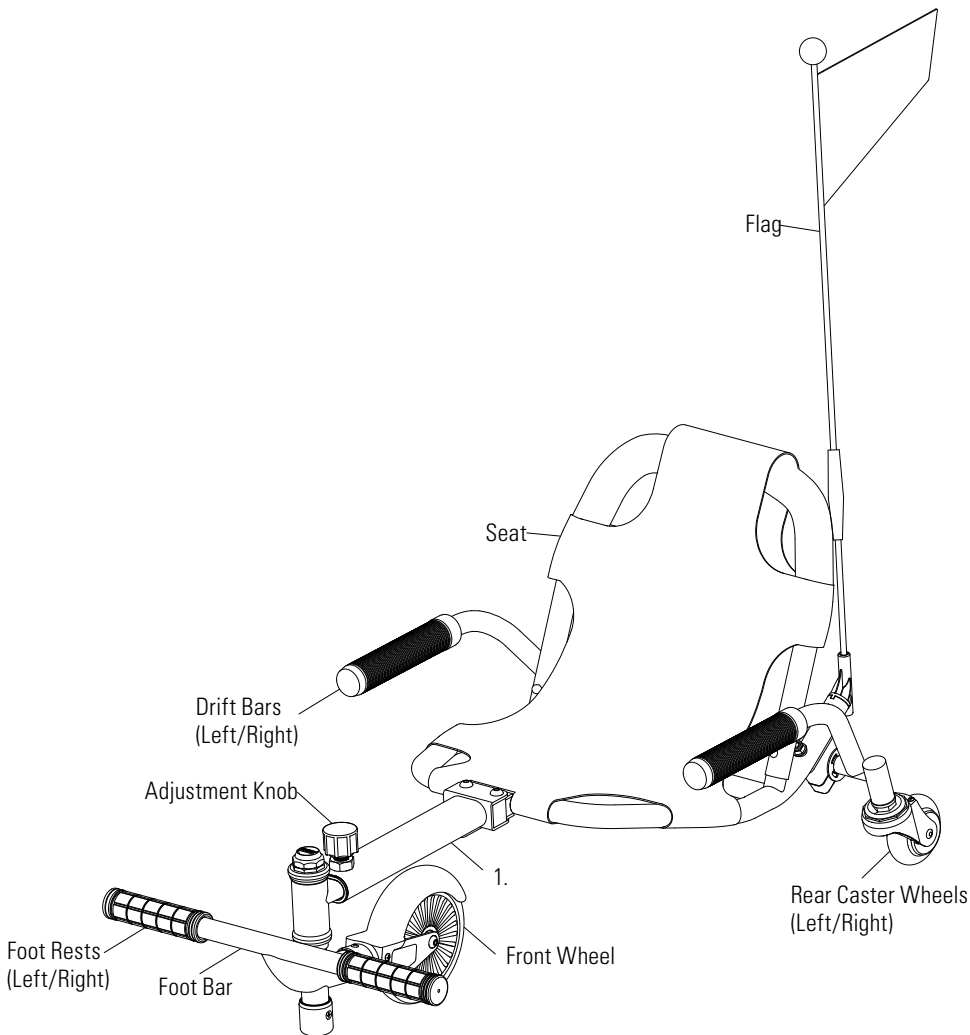

Required Tools

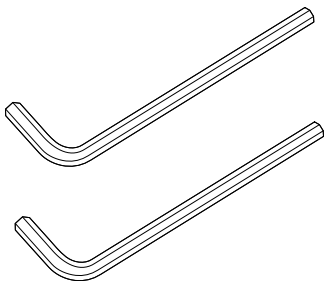

Two (2) 5 mm Allen Wrenches (included)

WARNING: DO NOT USE NON-RAZOR PRODUCTS WITH YOUR CRAZY CART SHUFFLE. The Crazy Cart Shuffle has been built to certain Razor design specifications. The original equipment supplied at the time of sale was selected on the basis of its compatibility with the frame, fork and all other parts. Certain aftermarket products may not be compatible and will void your warranty.

Product ID Locations:
(See locations to the left)
1. Frame (underneath unit)
2. Barcode on side of box (not shown)

Plastic Bag Contents:

- 5 mm Allen Wrenches
- Owner's Manual

ASSEMBLY AND SET-UP

□ Attaching the Seat

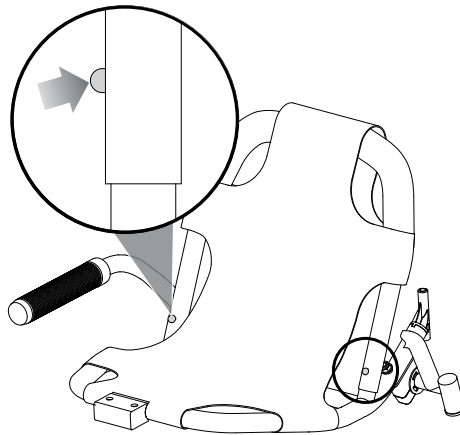
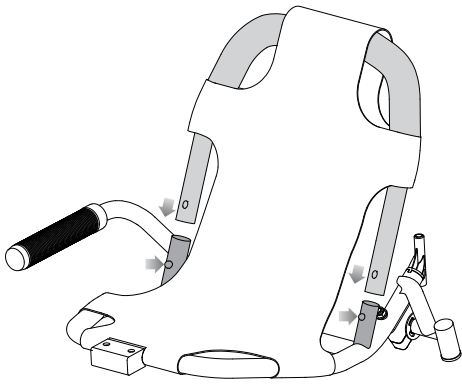

1 Slide the seat back frame tubes (left and right) on to the seat bottom frame tubes (left and right) until they hit the spring-loaded buttons on the seat bottom frame tubes. Press both spring-loaded buttons (left and right) on the seat bottom frame tubes simultaneously to slide down and install the seat back frame tubes onto the seat bottom frame simultaneously.

2 The spring-loaded buttons will pop out when properly installed.

⚠ WARNING: Failure to properly engage the spring-loaded buttons may cause the seat to dislodge while riding and may cause you to lose control. When correctly engaged the seat will not rotate nor will it move sideways. Note that when properly engaged, the spring-loaded buttons are clearly visible in the holes on the seat frame.

□ Attaching the Frame

Required Tools: Two (2) 5 mm Allen Wrenches (included)

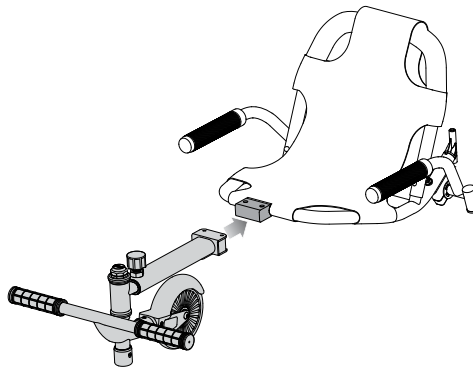
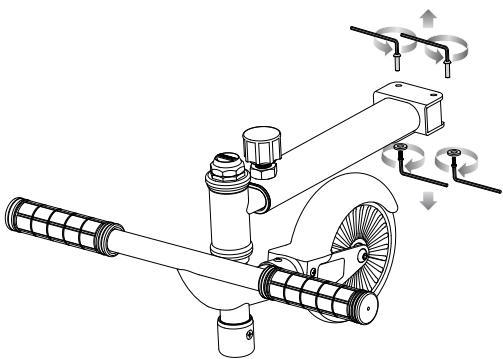

1 Using two (2) 5 mm Allen wrenches, remove the four (4) bolts on the front half of the frame.

2 Install the front half of the frame to the rear half of the frame, making sure that all holes align.

⚠ WARNING: Failing to properly tighten the bolts on the frame can cause you to lose control.

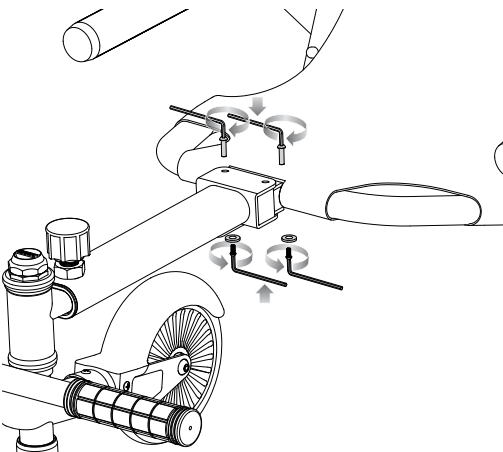

3 Using two (2) 5 mm Allen wrenches, install the four (4) bolts through the frame.

ASSEMBLY AND SET-UP

□ Attaching the Rear Caster Wheels

Required Tool: 5 mm Allen Wrench (included)

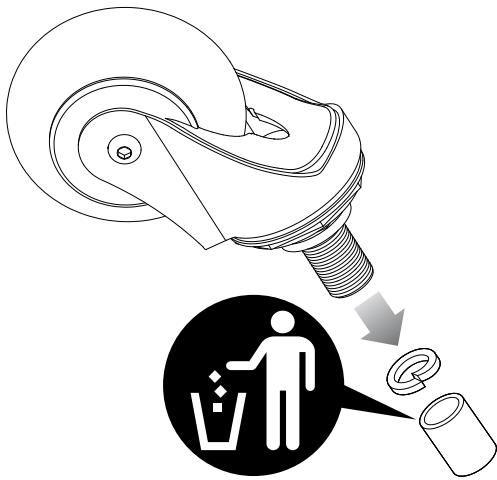

1 Remove the plastic packing material from the caster wheel. Discard the plastic packing material.

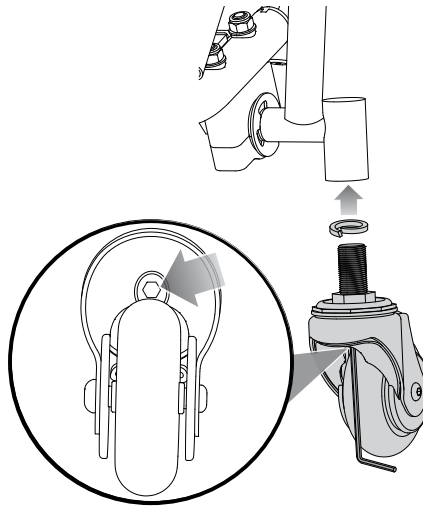

2 Put the wheel screw into the frame tube and using a 5 mm Allen wrench, tighten the bolt under the rear wheel caster.

⚠ WARNING: Failure to properly tighten the bolts that affix the wheels can cause you to lose control and crash.

Note: Practice riding only in wide open areas clear from curbs, parking blocks and other obstacles. Impacting the wheels against any hard surface can damage the wheels. Wheels are not covered under your limited warranty.

ASSEMBLY AND SET-UP

□ Adjusting the Frame Length

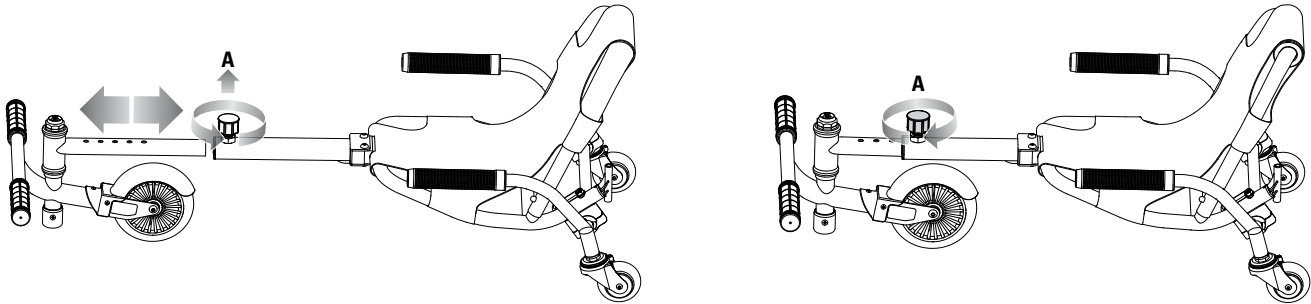

1 Locate Adjustment Knob (A). Turn knob to the left to loosen and the pull knob up. Slide and adjust the frame to the preferred length.

2 Turn Adjustment Knob (A) to the right to lock into place.

□ Attaching the Flag

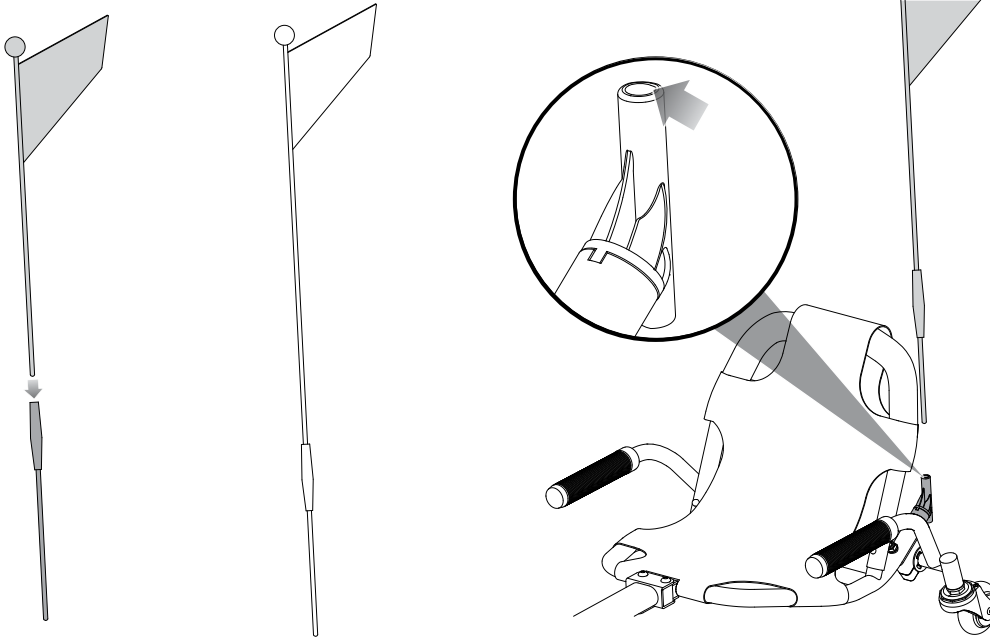

1 Assemble the flag as shown.

2 Insert flag into fixed hole located behind the seat.

PRE-RIDE CHECKLIST



Wheels

Periodically inspect the wheels for excess wear.



Frame, Fork and Drift Bars

Check for cracks or broken connections. Although broken frames are rare, it is possible for an aggressive rider to run into a curb or object and wreck and bend or break the frame. Get in the habit of inspecting your product on a regular basis.



Hardware/Loose Parts

Check and secure all fasteners before every ride. Make sure the bolts and casters are tight. There should not be any unusual rattles or sounds from loose parts or broken components. If the unit is damaged, do not ride. **Reference “Safety Warnings” on page 1 of this manual.**



Safety Gear

Always wear proper protective gear, such as an approved safety helmet. Elbow pads and kneepads are recommended. Always wear closed toe shoes (lace-up with rubber soles) and keep shoelaces tied and out of the way of the wheels. **NEVER RIDE BAREFOOTED OR IN SANDALS.**



Laws and Regulations

Always check and obey any local laws or regulations.



Be Careful!

This product is not for aggressive or trick riding. Avoid steep inclines and don't ride too fast — you can lose control and fall. Skateboard parks are not designed for young riders. Never ride in traffic or on the street and watch your surroundings for pedestrians, bikers, boarders and skaters.

Maintain a hold on the Drift Bars at all times.

USAGE

How to Ride

The Crazy Cart Shuffle is designed for learning at a slow pace. While seated, grasp grips on the Drift Bars and place both feet on the Foot Bar. Using feet, move the Foot Bar from side-to-side to propel the product. Using hands, move Drift Bars up and down to spin and drift. **Maintain a hold on the Drift Bars at all times.**

How to Move Forward

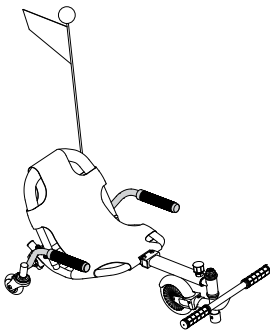

With the Drift Bars down, move the Foot Bar from side-to-side to propel the product forward.

How to Turn Left

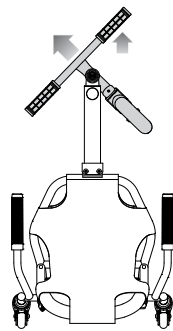

Push the right side of the Foot Bar with your foot to turn left.

How to Turn Right

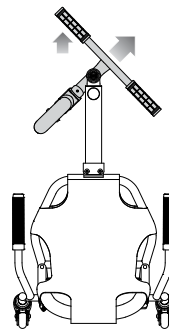

Push the left side of the Foot Bar with your foot to turn right.

How to Drift and Spin

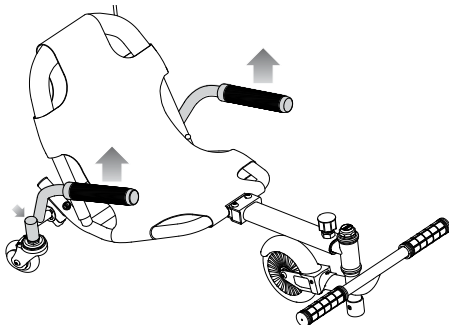

While turning in either direction, pull up the Drift Bars to initiate drifts and spins. Use Foot Bar to control your rotation and direction of travel.

Razor recommends that you practice drifting and spinning in an open area free from obstructions before riding your Crazy Cart Shuffle around others.

⚠ WARNING: When riding, both feet must be placed securely on Foot Bar.

⚠ WARNING: Do not allow hands, feet, hair, body parts, clothing, or similar articles to come in contact with the wheels or other moving components.

USAGE

□ How to Stop

This product has no brake. Place your feet on the ground and lower the Drift Bars to slow and stop. Make certain feet are placed on the sides (not in front of the Foot Bar before dismounting to either side).

Note: Do not step out of Crazy Cart Shuffle until unit has come to a complete stop.

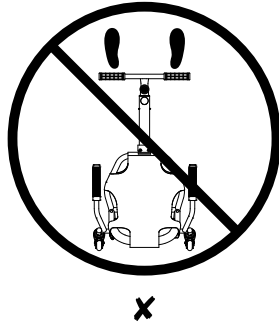
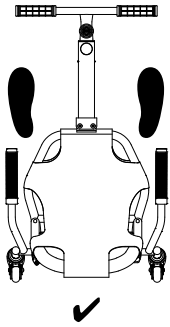

REPAIR AND MAINTENANCE

□ Cleaning

Wipe with a damp cloth to remove dirt and dust. Do not use industrial cleaners or solvents, as they may damage the surfaces. Do not use alcohol, alcohol-based or ammonia-based cleaners, as they may damage or dissolve the plastic components or soften the decals or decal adhesive.

□ Wheels and Bearings

Under normal circumstances and conditions, Razor wheels and wheel bearings are maintenance free. Nonetheless, it is the responsibility of the owner or guardian to periodically inspect the wheels for wear and tear, the axle for proper tightness, bearings for side-to-side play, and for loose parts. When a wheel develops play, this is an indication of excess wear and replacement is necessary. Replace immediately with only genuine Razor wheels. Worn wheels/bearings are considered normal wear-and-tear and are not covered by the Razor Warranty. Wheels other than genuine Razor wheels may not be compatible with your Razor product.

CRAZY CART SHUFFLE PARTS

Keep your Crazy Cart Shuffle rolling for years with genuine Razor parts. (Specifications subject to change without notice.)

- | | | | |
|---|--|---|----------------------|
| 1. Foot Grips (x2) | 6. Front Adjustment Frame | 10. Drift Bar Clamps (Upper/Lower) | 14. Seat Support Bar |
| 2. Foot Bar / Front Fork
2-1 Anti-Tipping Pole | 7. Rear Adjustment Frame
7-1 Coupling Bolt
7-2 Flat Washer
7-3 Bolt | 11. Rear Axle / Drift Bar
11-1 C-Type Circlip (x2) | 15. Seat Pad |
| 3. Front Fender | 8. Adjustment Knob | 12. Drift Bar Grips (x2) | 16. Seat |
| 4. Front Wheel Complete | 9. Rear Frame | 13. Rear Caster w/ Wheels (x2) | 17. Flag |

