



ECOSMART™ CARGO™

ADULT ELECTRIC UTILITY SCOOTER



OWNER'S MANUAL

**Read and understand this entire manual before
using this product!**

**NOTE: Manual illustrations are for demonstration purposes only.
Illustrations may not reflect exact appearance of actual product.
Specifications subject to change without notice.**

www.razor.com/mx
Hecho en China

CONTENTS

Safety Warnings.....	1-2	Repair and Maintenance.....	11-13
Before You Begin.....	3	Troubleshooting Guide.....	14-15
Assembly and Set-Up.....	4-6	EcoSmart Cargo Parts.....	16
Charging the Battery.....	7		
Pre-Ride Checklist.....	8		
Usage.....	9-10		

INTRODUCTION: RAZOR ECOSMART CARGO ADULT ELECTRIC UTILITY SCOOTER

THE RAZOR ECOSMART CARGO IS FOR ADULT USERS AND SHOULD ONLY BE RIDDEN CAREFULLY AND RESPONSIBLY BY APPROPRIATELY MATURE AND RESPONSIBLE RIDERS AND PASSENGERS EXERCISING CAUTION AND RESPECTING APPLICABLE LAWS.

The Razor EcoSmart Metro scooter has been part of Razor's fifteen years of experience as a leader in motorized scooter technology. Our original EcoSmart is now refreshed with many improvements, but this edition retains Razor's original chain-driven configuration.

This product is not a toy for young riders! Razor emphasizes, therefore, the importance of riders to understand the risks associated with using literally any wheeled product around vehicle or pedestrian traffic and the specific risks of riding an electric scooter. Bluntly put, you could get hurt and your actions could cause injury to others. You must be cautious, alert and take reasonable precautions to minimize such risks of falls, impacts or other problems.

The user must be, and is, responsible for determining whether local laws permit use of the EcoSmart Cargo in varying circumstances (there is no "uniform Federal law" in existence to establish universal riding conditions). The rider must be, and is, responsible for acting maturely, carefully, and with respect for local rules of the road when riding, and the rider must be, and is, responsible for assessing and minimizing effects of potentially adverse riding conditions including darkness or impaired visibility, fog, rain, snow, hail, ice or electrical storms, which increase dangers inherent in operating any scooter. The rider must be, and is, responsible for adjusting riding behavior and braking distance to suit the weather and traffic conditions, and also to recognize that riding in low visibility conditions decreases your ability to see and be seen, especially on public streets and around vehicles or pedestrians. The Razor EcoSmart Cargo head- and tail-lights may reduce such risks, and riders also are encouraged to seek to enhance their visibility/conspicuity through use of higher visibility garments, lights or other reflective materials when riding in reduced visibility circumstances. Razor absolutely recommends that any rider wear a proper helmet to minimize potential head injuries.

Use of the EcoSmart Cargo scooter is recommended for mature riders – using age 18+ (the generally recognized age of "legal consent") as a guide. Riders of the EcoSmart Cargo certainly must respect and adhere to all locally applicable laws and rules applicable to the use of such products. And if you're going to ride near cars, be legal and be safe!

SAFETY WARNINGS

⚠ WARNING: Riding an EcoSmart Cargo does present potential risks and caution is required. Certain conditions may cause the equipment to fail without fault of the manufacturer. Like any riding product, an EcoSmart Cargo has inherent hazards associated with its use (for example, falling off or riding it into a hazardous situation). Like any riding product, EcoSmart Cargo can and is intended to move and it is therefore, of course, possible to lose control or otherwise get into dangerous situations. Riders must recognize that if such things occur, a rider can be seriously injured or die even when using safety equipment and other precautions. RIDE AT YOUR OWN RISK AND USE COMMON SENSE.

This manual contains important safety information. It is your responsibility to review this information and make sure that all riders understand all warnings, cautions, instructions and safety topics and assure that young riders are able to safely and responsibly use this product. Razor recommends that you periodically review and reinforce the information in this manual with younger riders, and that you inspect and maintain your teen's scooter to ensure their safety.

This manual contains many warnings and cautions concerning the consequences of failing to maintain, inspect or properly use your EcoSmart Cargo electric scooter. Because any incident can result in serious injury or even death, we do not repeat the warning of possible serious injury or death each time such a possibility is mentioned.

⚠ WARNING: Always check and obey any local laws or regulations which may affect the locations where the EcoSmart

Cargo may be used. Keeping away from cars and motor vehicle traffic provides the highest protection against risk of traffic-related injuries, of course. For mature riders seeking to operate this product as legally permitted for commuting applications, the increased risks presented by traffic certainly emphasizes that the need for caution, personal responsibility and compliance with local laws is imperative and is the rider's responsibility. Only use where allowed and with caution.

⚠ WARNING: PARENTAL AND ADULT RESPONSIBILITY AND SUPERVISION IS NECESSARY TO ASSURE USE BY MATURE RIDERS:

Because products, like EcoSmart Cargo, can and do present potential hazards plainly associated with their use, it is well recognized THE NEED FOR EXERCISE OF PARENTAL RESPONSIBILITY IN SELECTING RIDING PRODUCTS APPROPRIATE TO THE AGE OF A CHILD, OR PARENTAL SUPERVISION IN SITUATIONS IN WHICH CHILDREN OF VARIOUS AGES MAY HAVE ACCESS TO THE SAME RIDING PRODUCTS, IS IMPORTANT. Not every product is appropriate for every age or size of child, and different age recommendations are found within this category of product which are intended to reflect the nature of the hazards and the expected mental or physical ability, or both, of a child to cope with the hazards.

⚠ WARNING: NOT FOR RIDERS OR PASSENGERS UNDER AGE 18 OR HEAVIER THAN 300 LB TOTAL WEIGHT (136 KG). DO NOT EXCEED THE MAXIMUM RIDER PLUS PASSENGER/CARGO WEIGHT LIMIT OF 300 lb (136 kg). Exceeding the weight limit could injure the rider and/or adult passenger and damage the EcoSmart Cargo. Rider or adult passenger

SAFETY WARNINGS

weight alone also does not necessarily mean a person's size is appropriate to fit or maintain control of the EcoSmart Cargo. Keep this product away from small children and remember that this product is not a toy and is intended for use only by persons who are, at a minimum, completely comfortable and competent while operating the product.

Razor recommends that children under the age of 18 not be permitted to use this product. This recommendation is based not just on age or weight or height; it reflects consideration of expected maturity and skills as well as physical size. The recommended rider and adult passenger age of 18 years or older is only an estimate and can be affected by the rider's and adult passenger's size, weight, or skills – not every rider or adult passenger 18 years old or older will be suited to the product. Certainly, any rider or adult passenger unable to fit comfortably on the EcoSmart Cargo should not attempt to ride it, but **a parent's decision to allow his or her teen to ride this product should be based on the teen's maturity, skill, and ability to follow rules. Razor emphasizes that adults are strongly advised not to disregard Razor's recommendations or permit younger children to ride the EcoSmart Cargo.**

Keep this product away from small children and remember that it is not a toy and is intended for use only by persons who are, at a minimum, completely comfortable and competent while operating.

Persons with any mental or physical conditions that may make them susceptible to injury, impair their physical dexterity or mental capabilities to recognize, understand, and follow safety instructions and to be able to understand the hazards inherent in the use of any ride-on product, should not use or be permitted to use products inappropriate for their abilities. Persons with heart conditions, head, back or neck ailments (or prior surgeries to these areas of the body), or pregnant women, should be cautioned not to operate such products.

DO NOT EXCEED THE MAXIMUM RIDER PLUS PASSENGER/CARGO WEIGHT LIMIT OF 300 lb (136 kg). Rider and adult passenger weight does not necessarily mean a person's size is appropriate to fit or maintain control of the EcoSmart Cargo.

CHECK AND MAINTAIN PRODUCT CONDITIONS

Before use, check to confirm that covers and guards are in place and in serviceable condition. Check that the brake is functioning properly, that the tires are inflated properly and have sufficient tread remaining. The product should be maintained and repaired in accordance with the manufacturer's specifications, using only the manufacturer's authorized replacement parts, and should not be modified from the manufacturer's original design and configuration.

ACCEPTABLE RIDING PRACTICES AND CONDITIONS

Do not activate the throttle unless you are on the EcoSmart Cargo and in a safe, outdoor environment suitable for riding. Once the throttle is activated the EcoSmart Cargo will move forward.

The normal powered top speed of this product will be approximately 19.9 mph (32 km/h), which can be affected by conditions, such as rider plus passenger/cargo weight, inclines and battery charge level. Avoid excessive speeds that can be associated with downhill rides.

Be careful and know your limitations. Risk of injury increases as the degree of riding difficulty increases. The rider and passenger assume all risk associated with aggressive riding activities.

Maintain a hold on the handlebars at all times. Do not touch the brake or motor on your scooter when in use or immediately after riding, as these parts can become very hot.

RAZOR RECOMMENDS ADULT PASSENGERS ONLY: This scooter product is not as large or as stable as things like cars or motorcycles. It is important that passengers do not interfere with balance or with rider control. Razor therefore recommends that passengers be mature and capable adults who understand the importance of these facts and can moderate their riding practices to avoid and prevent interference with safe operation of the EcoSmart Cargo scooter.

Ride defensively. Watch out for potential obstacles that could catch your wheel or force you to swerve suddenly or lose control. Be careful to avoid

pedestrians, skaters, skateboards, scooters, bikes, children or animals who may enter your path, and respect the rights and property of others.

The EcoSmart Cargo is intended for use on flat, dry surfaces, such as pavement or level ground, without loose debris, such as sand, leaves, rocks or gravel. Wet, slick, bumpy, uneven or rough surfaces may impair traction and contribute to possible accidents. Do not ride your product in mud, ice, puddles or water. Watch out for potential obstacles that could catch your wheel or force you to swerve suddenly or lose control. Avoid sharp bumps, drainage grates, and sudden surface changes.

Do not attempt or do stunts or tricks. The EcoSmart Cargo is not made to withstand abuse from misuse, such as jumping, curb grinding or any other type of stunts. Racing, stunt riding, or other maneuvers also enhance risk of loss of control, or may cause uncontrolled rider actions or reactions.

Riding at night or when visibility is limited increases risks of accident or injury. Should the EcoSmart Cargo scooter be ridden in such conditions, use of lights and additional measures to increase rider visibility and scooter conspicuity are advised.

Never use near steps or swimming pools.

Do not allow hands, feet, hair, body parts, clothing, or similar articles to come in contact with moving parts or wheels while the motor is engaged.

Do not touch electric motor or brake when in use or immediately after riding.

Never use headphones or a cell phone to talk or text when riding.

Never ride your product while under the influence of drugs or alcohol.

Never hitch a ride with a vehicle.

The EcoSmart Cargo electric scooter can operate more quietly than other motorized products may operate. Use care when in the vicinity of pedestrians or others who may have difficulty hearing your approach. Use handbell (not included) to sound warnings when appropriate.

Never risk damaging surfaces such as carpet or flooring by use of an EcoSmart Cargo electric scooter indoors.

Refer to the section on safety reminders for additional warnings.

PROPER RIDING ATTIRE

Always wear proper protective equipment, such as an approved safety helmet (with chin strap securely buckled), elbow pads, and kneepads. A helmet may be legally required by local law or regulation in your area. A long-sleeved shirt, and long pants are recommended. Always wear athletic shoes (lace up shoes with rubber soles), never ride barefooted or in sandals, and keep shoelaces tied and out of the way of the wheels, motor and drive system.

USING THE CHARGER

The charger supplied with the product should be regularly examined for damage to the cord, plug, enclosure and other parts. In the event of such damage, the product must not be charged until the charger has been repaired or replaced.

Use only with the recommended charger.

Use caution when charging.

The charger is not a toy. Charger should be operated by an adult.

Do not operate charger near flammable materials.

Make sure power switch is in the "off" position, unplug charger and disconnect from product when not in use.

Always disconnect from the charger prior to wiping down and cleaning your product with damp cloth.

FAILURE TO USE COMMON SENSE AND HEED THE ABOVE WARNINGS FURTHER INCREASES RISK OF SERIOUS INJURY. USE AT YOUR OWN RISK AND WITH APPROPRIATE AND SERIOUS ATTENTION TO SAFE OPERATION. USE CAUTION.

BEFORE YOU BEGIN

Remove contents from box. Remove the separators that protect the components from damage during shipping. Inspect the contents of the box for scratches in the paint, dents, or kinked cables that may have occurred during shipping. Because the electric scooter was partially assembled and packed at the factory, there should not be any problems, even if the box has a few scars or dents.

MAKE SURE POWER BUTTON IS TURNED "OFF" BEFORE CONDUCTING ANY ASSEMBLY OR MAINTENANCE PROCEDURES.

Estimated Assembly and Set-Up Time

Razor recommends assembly by an adult with experience in bicycle mechanics. Allow up to 30 minutes for assembly, not including initial charge time. Allow up to 6 hours for charge (see page 7 for charging information).

Charger

Note: Charger design may vary from one shown

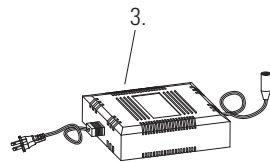

WARNING: DO NOT USE NON-RAZOR PRODUCTS WITH YOUR ELECTRIC SCOOTER.

Razor scooters have been built to certain Razor design specifications. The original equipment supplied at the time of sale was selected on the basis of its compatibility with the frame, fork and all other parts. Certain aftermarket products may not be compatible and will void the warranty.

Product ID Locations:
(See locations to the left)

1. Bottom of T-tube
2. Side of Battery Box
3. Charger
4. UPC Side of Box (Not Shown)

Box Contents:

- Electric Scooter
- Charger
- Owner's Manual
- Tools
- Basket

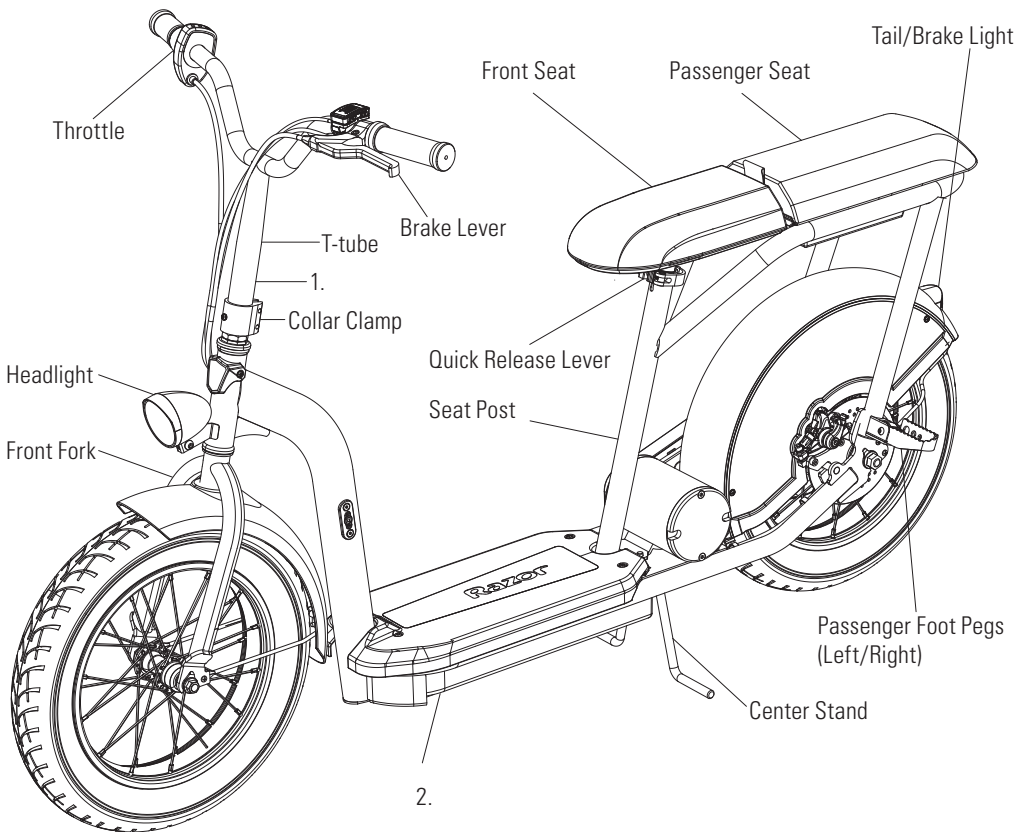

Required Tools

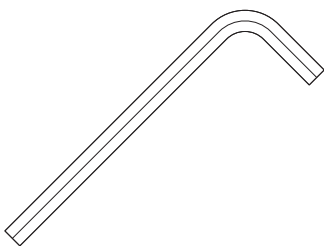

5 mm Allen Wrench (included)

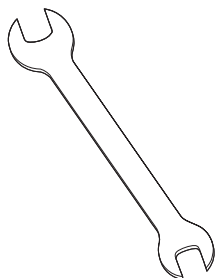

8/10 mm Wrench (included) and Two (2) 13/15 mm Wrenches (included)

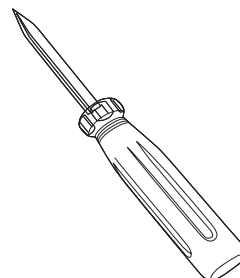

Phillips Screwdriver (not included)

ASSEMBLY AND SET-UP

□ Attaching the Front Wheel

Required Tools: Two (2) 15 mm Wrenches (included)

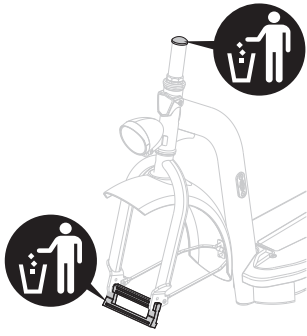

1 Remove the packing material from the front fork. Discard packing material.

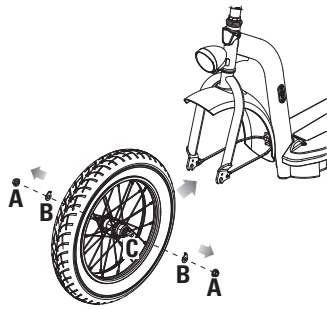

2 Remove axle nuts (A) and washers (B) from the axle bolt (C) and insert the wheel into the front fork.

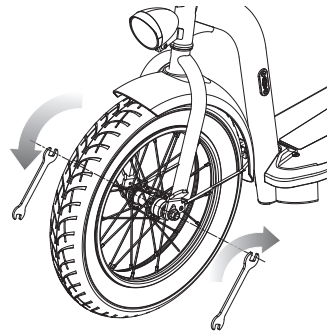

3 Insert the tab on the safety washers into the hole on the front fork and tighten axle nuts using two (2) 15 mm wrenches.

□ Attaching the Handlebars

Required Tool: 5 mm Allen Wrench (included)

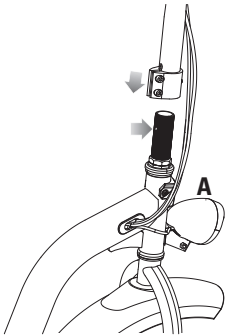

1 Face the handlebars forward with the throttle on the right and brake lever on the left, depress the push button (A) located on the front fork and insert the handlebar stem until the button locks securely into the stem.

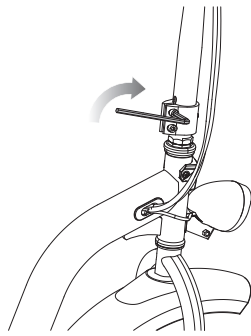

2 Tighten the collar clamp using a 5 mm Allen wrench.

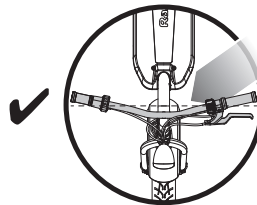
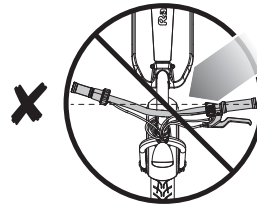

⚠ WARNING: Failure to properly install and tighten the collar clamp may allow the handlebars to dislodge while riding and may cause you to lose control and fall. When correctly tightened, the handlebars will not rotate out of alignment with the front wheel under normal circumstances.

Note: The cable and wire assembly from the handlebar must not be wrapped around the steering tube or handlebar. Sharp bends or twisting of the brake cable can cause the brake to malfunction.

ASSEMBLY AND SET-UP

□ Adjusting the Front Seat Height

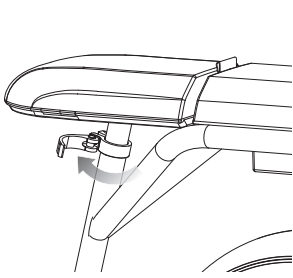

1 To adjust the height of the front seat, open the quick-release lever on the seat post.

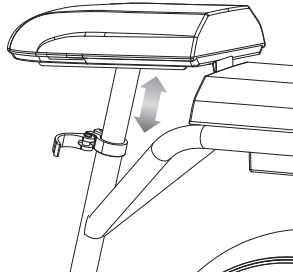

2 Slide the seat to the desired position.

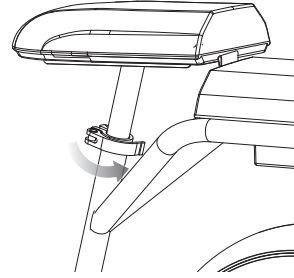

3 Lock the seat position by closing the quick-release lever on the seat post.

□ Adjusting the Front Seat Position

Required Tool: 10 mm Wrench (included)

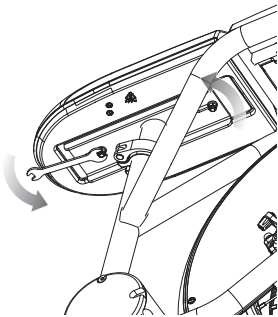

1 Using a 10 mm wrench, loosen the two (2) lock nuts below the front seat.

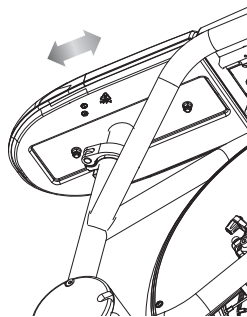

2 Adjust seat forward or back to the desired position.

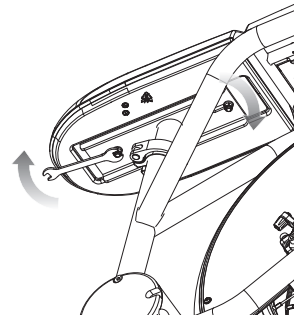

3 Using a 10 mm wrench, tighten the two (2) lock nuts below the front seat to lock the seat in position.

□ Inflating the Tires

The tires are inflated when shipped, but they invariably may lose some pressure between the point of manufacturing and your purchase. **Always inflate tires to the correct PSI before first time use.**

Lower air pressure can result in a shorter ride time.

Periodically check tires. Reinflate when needed.

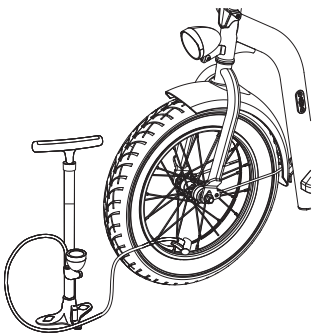

Remove the valve cap and using a bicycle style tire pump equipped for a Schrader-type valve, inflate the tires to the correct PSI indicated on the sidewall of the tire. Replace the valve cap.

⚠ WARNING: Failure to properly secure the quick-release lever may cause the seat to telescope up or down while riding and may cause you to lose control and fall.

⚠ WARNING: Failure to properly secure the lock nuts on the front seat may cause the seat to move forward or back while riding and may cause you to lose control and fall.

⚠ WARNING: Do not use the electric scooter for the first time until you have inflated the tires to the correct PSI. Failure to do so may damage your electric scooter and void your warranty.

⚠ WARNING: Do not overinflate, as this could damage the tires or wheels.

Note: The pressure air supplies found at gasoline stations are designed to inflate high-volume automobile tires. If you decide to use such an air supply to inflate your electric scooter tires, first make sure the pressure gauge is working, then use very short bursts to inflate to the correct PSI. If you inadvertently overinflate the tires, release the excess pressure immediately.

ASSEMBLY AND SET-UP

□ Removing the Passenger Seat

Required Tool: Phillips Screwdriver (not included)

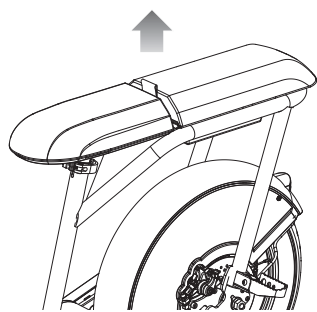

1 Pull strap on passenger seat.

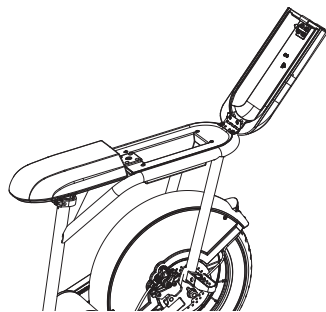

2 Open storage compartment.

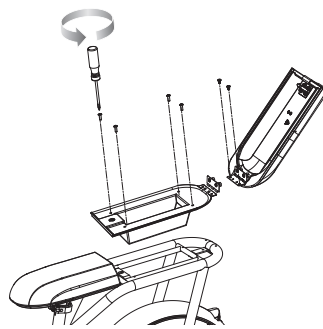

3 Using a Phillips screwdriver, remove the six (6) screws that secure the storage compartment and the passenger seat to the rear frame. Remove the storage compartment and passenger seat and store for future use. To reinstall passenger seat, reverse steps 1-3.

□ Installing the Basket

The passenger seat must be removed before basket installation. Passenger seat and basket cannot be installed on EcoSmart Cargo at the same time.

Required Tool: 5 mm Allen Wrench (included)

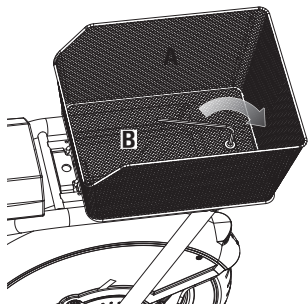

1 Slide the basket hooks (A) under the crossbar (B) located on the rear frame.

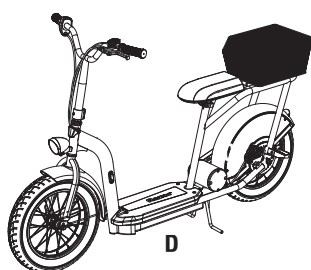

2 Align the hole in the basket (C) with the hole on the rear frame (D). Insert the washer and bolt into the hole in the basket and through the bracket on the rear frame.

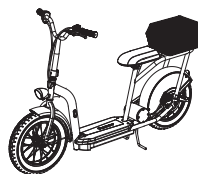

3 Using a 5 mm Allen wrench, tighten the bolt until the basket is securely attached to the rear frame.

Note: For basket removal, reverse steps 1-3. After removal, store basket for future use.

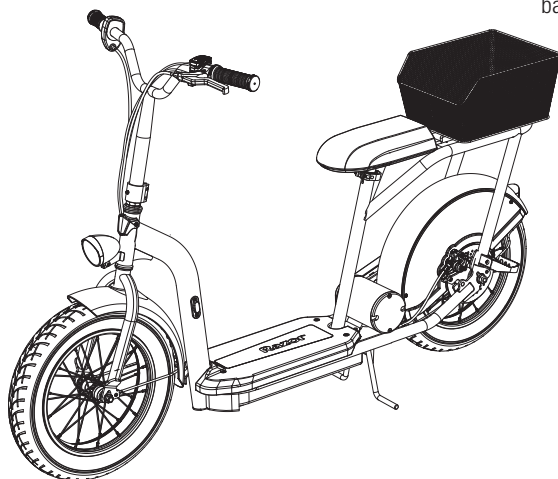

⚠ WARNING: The basket should not be used to carry people or pets.

CHARGING THE BATTERY

Your electric scooter may not have a fully charged battery; therefore you must charge the battery prior to use. Be sure to charge the battery in a clean, dry location away from direct sunlight, flames or sparks.

- Initial charge time: 6 hours.
- Recharge time: up to 6 hours, even if the light turns green. Recommended maximum charging time is 24 hours.
- Always charge the battery immediately after riding.
- Fully charge battery before storing for extended periods of time.
- Unplug charger from the wall outlet when not in use.
- Failure to recharge battery periodically may result in a battery that will not accept a charge.
- Make sure the power is turned OFF when product is not in use. If the ON/OFF button is left on for an extended period of time, the battery may reach a stage at which it will no longer hold a charge.
- Run time: Up to 50 minutes of continuous ride time. Run time may vary depending on riding conditions, rider weight, climate, and/or proper maintenance.
- Constant starting and stopping may shorten ride time.
- Battery life can vary depending on proper maintenance and usage of the product.
- Do not charge at or below 32°F (0°C).

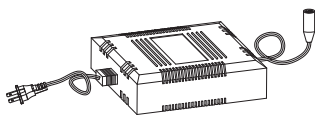

Charger

Note: Charger design may vary from one shown

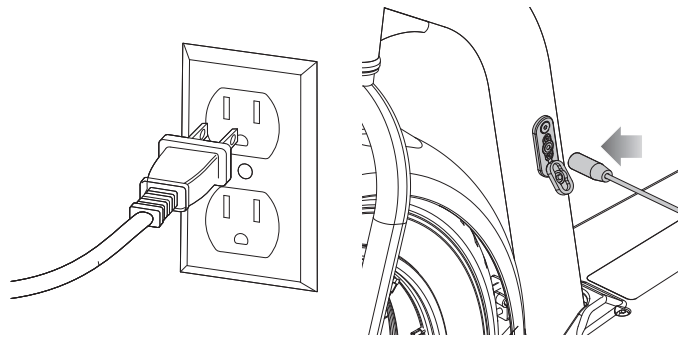

1 Plug the charger plug into wall outlet. The light on the charger should be green.

Note: If green light (LED) does not turn on, try a different outlet.

2 Note: Make sure power button is in the **OFF** position. Plug the charger into the charger port. The light on the charger should turn red during charging. The light will turn green again when charging is complete.

Model	Voltage (Nominal) Vdc	Capacity (Nominal) Ah	Charge Temperature Range	Operating Temperature Range
EcoSmart Cargo	46.8	7.6	0° to 40°C 32° to 104°F	-20° to 40°C -4° to 122°F

Note: If your charger does not look like the one illustrated, your unit has been supplied with an alternative charger. The specifications and charging procedure would not change.

⚠ WARNING: Use **ONLY** with the recommended charger. Batteries are only to be charged under adult supervision. The charger is not a toy. Always disconnect the charger before wiping down and/or cleaning the electric scooter with a damp cloth.

The charger supplied with the electric scooter should be regularly examined for damage to the cord, plug, enclosure and other parts. In the event of such damage, the electric scooter must not be charged until it has been repaired or replaced.

Chargers have built-in overcharge protection to prevent battery from being overcharged.

Be sure to properly align the groove on the charger input plug with the corresponding socket on the case; otherwise, no charging action will occur.

Note: If the charger gets warm during regular use, this is a normal response and is no cause for concern. If your charger does not get warm during use, it does not mean that it is not working properly.

Wall outlet - Green (stand by)
Wall outlet and unit - Red (charging)
Wall outlet and unit - Green (charged)

Note: Continue charging unit even if light turns green prior to 6 hours.

⚠ WARNING: Battery charge can deplete over time. Periodically recharge battery when not in use.

PRE-RIDE CHECKLIST



Lights

Check the head- and tail-lights for proper function. When you activate the lights (reference "How to Ride" on page 9 of this manual), the headlight and taillight should illuminate.



Brake

Check the brake for proper function. When you squeeze the brake lever, the brake should provide positive braking action. Make sure brake is not rubbing when the lever is released. When you apply the brake with the throttle on/engaged, the brake cut-off switch should cut power to the motor.



Wheels

Periodically inspect the wheels for excessive wear.



Tires

Periodically inspect the tires for excess wear and replace as needed. Regularly check the tire pressure and inflate as needed. If you get a flat tire, the inner tube can be patched or a new tube can be purchased from Razor or an authorized repair center.



Frame, Fork and Handlebars

Check for cracks or broken connections. Although broken frames are rare, it is possible for an aggressive rider to run into a curb or object and wreck, bend or break a frame. Get in the habit of inspecting your scooter on a regular basis.



Hardware/Loose Parts

Before every ride, check all parts, such as nuts, bolts, fasteners, etc., to ensure they are secure and assembled correctly. There should not be any unusual rattles or sounds from loose parts or broken components. If the product is damaged, do not ride.

Reference "Safety Warnings" on pages 1 and 2 of this manual.



Safety Gear

Always wear proper protective equipment, such as an approved safety helmet (with chin strap securely buckled), elbow pads, and kneepads. A helmet may be legally required by local law or regulation in your area. A long-sleeved shirt and long pants are recommended. Always wear shoes and keep shoelaces tied and out of the way of the wheels and motor and drive system.

NEVER RIDE BAREFOOTED OR IN SANDALS.



Laws and Regulations

Always check and obey any local laws or regulations.



Insurance

Do not assume that your existing insurance policies necessarily provide coverage for product use. Check with your insurance company for information regarding insurance.



Storage

Prolonged exposure to UV rays, rain and the elements may damage the enclosure materials, store indoors when not in use.

USAGE

□ How to Operate

Do not activate the twist-grip throttle unless you are on the electric scooter and in a safe, outdoor environment suitable for riding. The throttle can be activated as soon as the power button turns the product on.

□ How to Ride

Once you have inflated the tires (see page 5) and charged the battery (see page 7):

1. Move EcoSmart Cargo slightly forward to retract center stand.
2. Turn power "ON" by pressing the power button **(A)** for two seconds. The display will light up.
3. Sit on the front seat of the EcoSmart Cargo with both feet on the ground on either side of the deck to balance the electric scooter.
4. Place both hands on the handlebars.
5. Place one foot on deck plate. Twist the throttle with right hand **(B)**. Place other foot on deck plate once scooter is in motion.

Note: Keep both feet on the deck while the EcoSmart Cargo is in motion.

Headlight and Taillight: To activate the headlight and taillight the product must be powered **ON**. Press the light button **(C)** once to activate the headlight and taillight. To deactivate the headlight and taillight, press the light button once again.

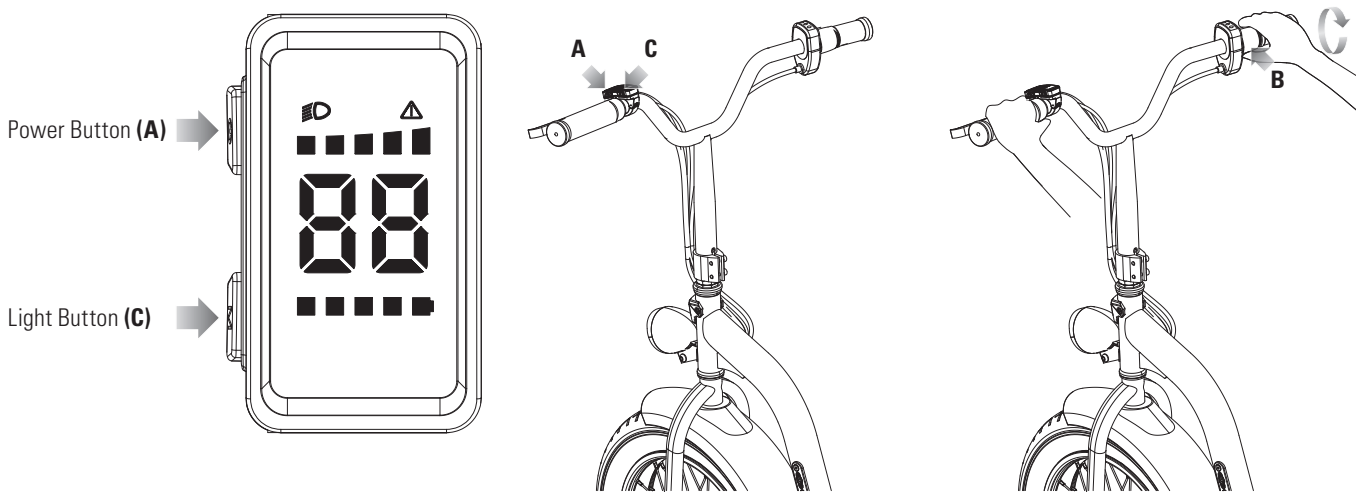

□ How to Use Passenger Seat

RAZOR RECOMMENDS ADULT PASSENGERS ONLY: This scooter product is not as large or as stable as things like cars or motorcycles. It is important that passengers do not interfere with balance or with rider control. Razor therefore recommends that passengers be mature and capable adults who understand the importance of these facts and can moderate their riding practices to avoid and prevent interference with safe operation of the EcoSmart Cargo scooter.

- Riders controlling the electric scooter should never sit on the passenger (rear) seat while riding. Electric scooter should only be controlled by rider sitting in the front seat.
- Passenger must keep both feet on foot pegs while electric scooter is in motion.

USAGE

□ How to Stop

1. To stop, release the throttle (**B**) and apply the brake, by squeezing the brake lever (**D**), until the product comes to a **complete stop**. When coming to a complete stop, place both feet on the ground to balance the electric scooter.
2. Make sure to turn the product **OFF** after your ride is complete. Pressing the power button (**A**) for two seconds will turn the product **OFF** completely.

Note: When the brake is applied the tail/brake light will flash. The brake light is always functional and independent of the other lights being activated.

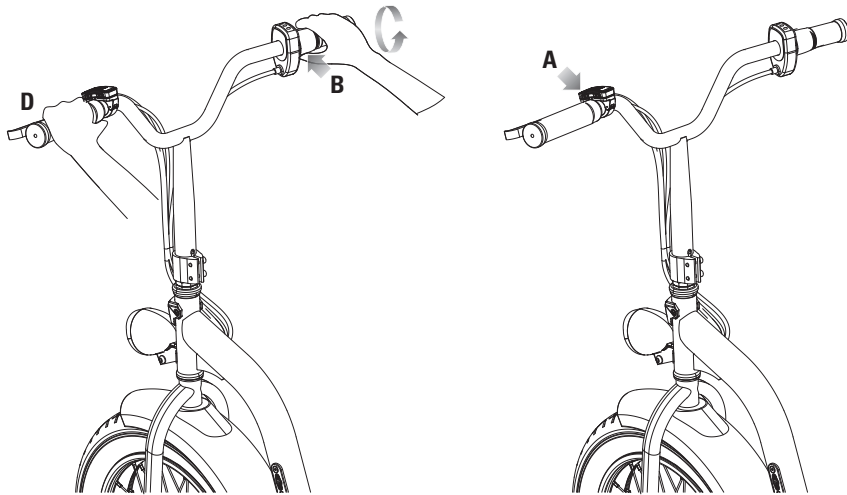

⚠ WARNING: The brake is capable of skidding the rear tire and throwing an unsuspecting rider. Practice in an open area free from obstacles until you are familiar with the brake function. Avoid skidding to a stop as this can cause you to lose control and/or damage the rear tire.

Note: As an additional safety feature, the scooter is designed to cut power to the motor when the hand brake is applied.

Note: Practice riding only in wide open areas clear from curbs, parking blocks and other obstacles. Impacting the wheels against any hard surface can damage the wheels.

□ Changing the Speed Level

Speed levels are controlled on the display. The display is activated when the power on the EcoSmart Cargo is in the "ON" position. Practice in an open area free from obstacles until you are familiar with changing speed levels. Riders can toggle speed levels up or down while the EcoSmart Cargo is in motion. Higher speed levels will result in higher speeds and lower speed levels will result in lower speeds. There are five (5) speed levels. The EcoSmart Cargo is set on speed level 0 (no speed) setting at the factory.

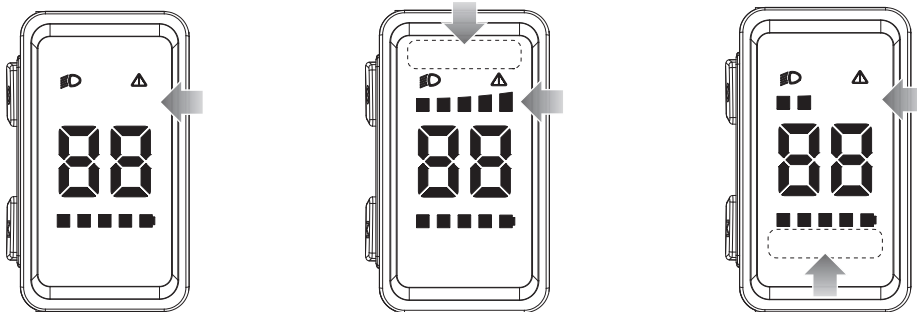

1 Each bar at the top of the display represents a speed level. When all the bars are off, EcoSmart Cargo is at speed level 0.

2 Press the top area of the display (as shown) to increase speed levels in increments of one (1). Each time you press the top area of the display you will move to the next higher speed level until you reach the maximum speed level (5).

3 Press the bottom area of the display (as shown) to decrease speed levels in increments of one (1). Each time you press the bottom area of the display you will move to the next lower speed level until you reach the lowest speed level (0).

Note: Once the electric scooter is powered OFF, speed levels are disabled. Speed level will reset to level 0 each time you power ON your electric scooter.

REPAIR AND MAINTENANCE

Turn power button "OFF" before beginning repair or maintenance:

- Read the instructions
- Remove charger plug
- Turn the power off
- Secure the product under repair
- Exercise caution around exposed parts
- Contact Razor customer service if unsure about any repair or maintenance
- Repair and maintenance should be performed by an adult only

□ Adjusting the Brake

Required Tool: 5 mm Allen Wrench (included)

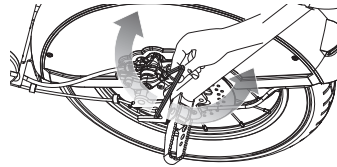
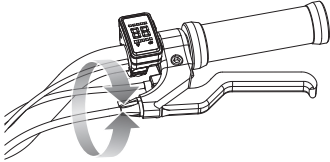

1 To adjust the brake cable tension, thread the brake lever adjuster in or out 1/4 to 1/2 turn until the desired brake adjustment is attained. Most adjustments are complete at this step. If brake still needs further adjustment, proceed to step 2.

2 If the brake has too much slack, loosen the rear anchor bolt with a 5 mm Allen wrench and pull the brake cable tight. The distance of the brake wire between the end of the cable and the anchor bolt should be between 37 mm and 44 mm.

□ Chain and Rear Wheel Replacement

Required Tools: 5 mm Allen Wrench (included), Phillips Screwdriver and Two (2) 19 mm Wrenches

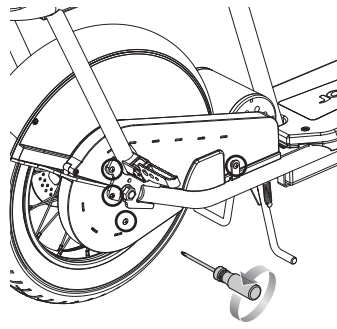
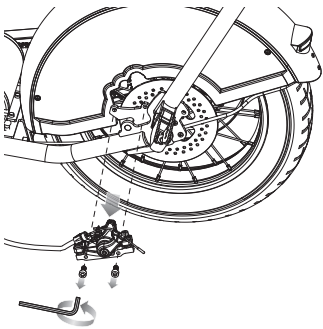

1 Using a 5 mm Allen wrench, remove the two (2) bolts from the brake caliper. Remove brake caliper and set aside.

2 Using a Phillips screwdriver, remove the four (4) screws from the chain guard. Remove chain guard and set aside.

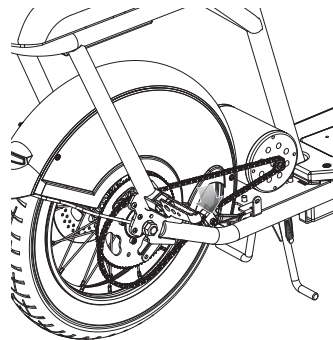
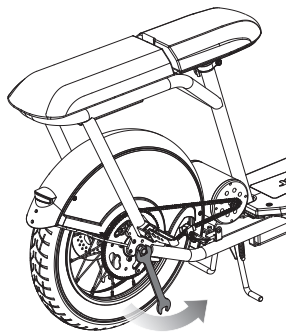
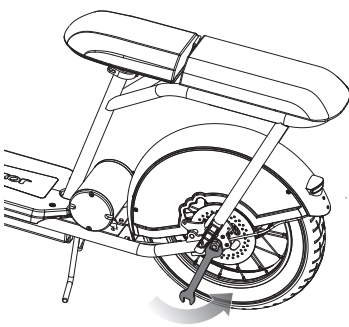

3 Using two (2) 19 mm wrenches, loosen the axle nuts.

4 Push the chain tensioner down to loosen the chain and remove the chain from the wheel sprocket and motor sprocket.

Note: Your hands will get greasy doing this.

⚠ WARNING: The brake is capable of skidding the rear tire and throwing an unsuspecting rider. Practice in an open area free from obstacles until you are familiar with the brake function. Avoid skidding to a stop as this can cause you to lose control and/or damage the rear tire.

REPAIR AND MAINTENANCE

Chain and Rear Wheel Replacement (Continued)

Required Tools: Phillips Screwdriver and Two (2) 19 mm Wrenches

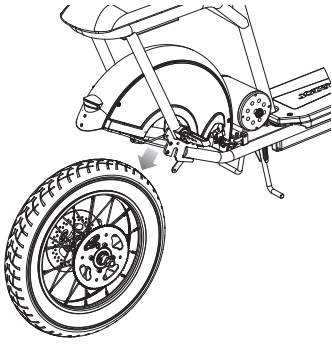

5 Push downward and remove the wheel.

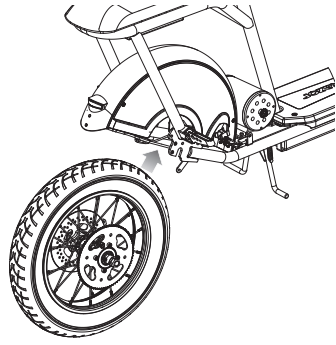

6 Install the new chain or wheel by slipping the chain around the axle. Slide the axle into the slots on the frame. Slide the chain tensioner onto the rear sprocket and motor sprocket.

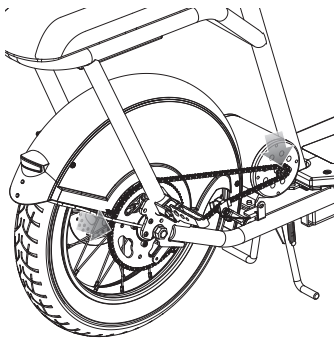
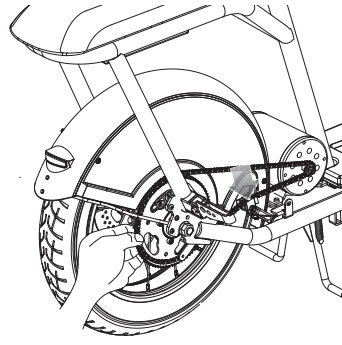

7 Verify that the chain is properly installed on each sprocket.

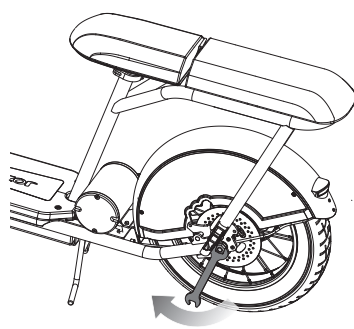

8 Using two (2) 19 mm wrenches, tighten the axle nuts on both sides of the rear axle.

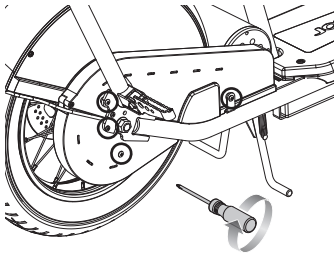
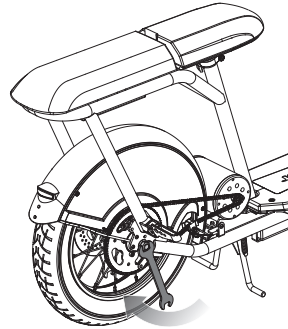

9 Using a Phillips screwdriver, reinstall the chain guard using the four (4) screws.

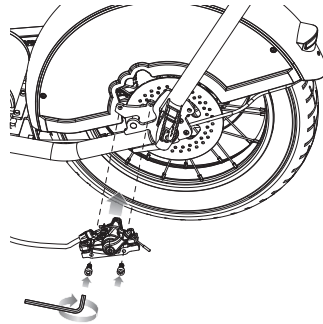

10 Using a 5 mm Allen wrench, reinstall the brake caliper using the two (2) bolts.

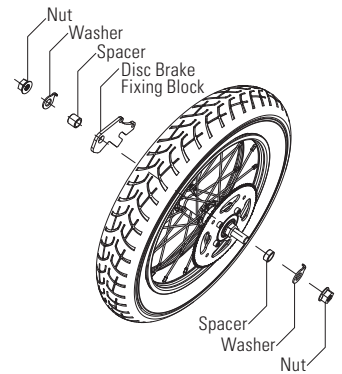

Note: the arrangement of the hardware sequence:

Right Side (Throttle)

- 16-1 Nut
- 16-2 Washer
- Frame
- 16-3 Spacer
- 16-4 Disc Brake Fixing Block

Left Side (Brake)

- 16-1 Spacer
- 16-2 Washer
- Frame
- 16-3 Nut

REPAIR AND MAINTENANCE

⚠ WARNING: Risk of fire - no user serviceable electrical parts.

Cleaning Your Scooter

Wipe with a damp cloth to remove dirt and dust. Do not use industrial cleaners or solvents as they may damage the surfaces. Do not use alcohol, alcohol-based or ammonia-based cleaners as they may damage or dissolve the plastic components or soften the decals or decal adhesive.

Battery Care and Disposal

Do not store in freezing or below freezing temperatures. To properly maintain your battery and ensure maximum battery life, carefully read the "Charging the Battery" section on page 7 of this owner's manual.



CONTAINS LITHIUM-ION BATTERY PACK. BATTERIES MUST BE RECYCLED.

Disposal: Your electric scooter uses a lithium-ion battery pack which must be recycled or disposed of in an environmentally safe manner. Do not dispose of a battery pack in a fire. The battery pack may explode.

Do not dispose of a battery pack in your regular household trash. The incineration, land filling or mixing of batteries with household trash is prohibited by law in most areas. Return exhausted batteries to a federal or state approved lithium-ion battery recycler.

Charger

The charger supplied with the electric scooter should be regularly examined for damage to the cord, plug, enclosure and other parts and in the event of such damage, the product must not be charged until it has been repaired or replaced.

Use ONLY with the recommended charger.

Not intended for use at elevations greater than 2000 m above sea level.

Wheels

Wheels and drive system are subject to normal wear and tear. It is the responsibility of the user to periodically inspect wheels for excess wear and replace drive train components as required.

Recycling Lithium-ion

Batteries: Lithium-ion batteries are recyclable. You can help preserve our environment by returning your used rechargeable batteries to the collection and recycling location nearest you.

TROUBLESHOOTING GUIDE

*Product(s) should be turned **OFF** and fully charged prior to doing any Troubleshooting.

NOTE: All troubleshooting steps should be performed by an adult only.

Problem	Possible Cause	Solution
Scooter does not run	Undercharged battery	Charge the battery. A new battery should have been charged for at least 6 hours before using the scooter for the first time and up to 6 hours after each subsequent use. Check all connectors. Make sure the charger connector is tightly plugged into the charging port and that the charger is plugged into the wall. Make sure the power flow to the wall outlet is on.
	Charger is not working	You may check to see if your charger is working by using a volt meter or ask your local Razor authorized service center to test your charger for you.
	Loose wires or connectors	Check all wires and connectors to make sure they are tight.
	Prolonged riding under overloaded conditions or in high temperature weather/environmental conditions	Battery may activate high temperature protection; battery must cool down before riding or charging can resume.
Short run time (less than 50 minutes per charge)	Undercharged battery	Charge the battery. A new battery should have been charged for at least 6 hours before using the scooter for the first time and up to 6 hours after each subsequent use. Check all wires and connectors. Make sure the battery connector is tightly plugged into the charger connector and that the charger is plugged into the wall. Make sure power flow to the wall outlet is on.
	Battery is old and will not accept full charge	Even with proper care, a rechargeable battery does not last forever. Average battery life is 1 to 2 years depending on scooter use and conditions. Replace only with a Razor replacement battery.
	Brake is not adjusted properly	Refer to adjusting the brake instructions on page 11.

TROUBLESHOOTING GUIDE

Problem	Possible Cause	Solution
Scooter runs sluggishly	Driving conditions are too stressful	Use only on solid, flat, clean and dry surfaces such as pavement or level ground.
	Tires are not properly inflated	The tires are inflated when shipped, but they invariably will lose some pressure between the point of manufacturing and your purchase. Refer to instructions on page 5 of this manual to properly inflate tires.
	Brake rotor is dragging on pads	Use your fingers to twist the caliper adjuster in either direction until rotor is centered between pads.
	Brake is not adjusted properly	Refer to adjusting the brake instructions on page 11.
Sometimes the scooter doesn't run, but other times it does	Loose wires or connectors	Check all wires around the motor and all connectors to make sure they are tight.
	Motor or electrical switch damage	
Charger gets warm during use	Normal response to charger use	No action required. This is normal for some chargers and is no cause for concern. If your charger does not get warm during use, it does not mean that it is not working properly.
Scooter does not stop when applying the brake	Brake is not adjusted properly	Refer to adjusting the brake instructions on page 11.
Scooter makes loud noises or grinding sounds	Chain is too dry	Apply a lubricant such as 3 in 1™ or Tri-Flow™ to the chain.
	Brake rotor is dragging on brake pads	Use your fingers to twist the caliper adjuster in either direction until rotor is centered between pads.

ECOSMART CARGO PARTS

Keep your EcoSmart Cargo running for years with genuine Razor parts. Visit our website or e-mail us for more information on spare part availability. (Specifications subject to change without notice.)

- | | | | |
|---------------------------------------|---------------------------|-------------------------|------------------------------------|
| 1. Handlebar Grip (Right/Left) | 8. Limiter Cover | 16. Control Module | 24. Rear Fender w/Brake/Tail Light |
| 2. Variable-Speed Twist-Grip Throttle | 9. Headlight | 17. Battery Tray | 25. Chain Tensioner |
| 3. Handlebar Stem | 10. Charger Port | 18. Motor 48 V 1000 W | 26. Rear Seat |
| 4. Display | 11. Front Fork | 19. Speed Sensor | 27. Quick-Release Seat Lever |
| 5. Brake Lever Assembly | 12. Front Wheel | 20. Brake Caliper | 28. Front Seat w/Post |
| 6. Collar Clamp | 13. Front Fender | 21. Rear Wheel Complete | 29. Deck Plate |
| 7. Headset (Upper/Lower) | 14. Battery 46.8 V 7.6 Ah | 22. Chain | |
| | 15. Center Stand | 23. Chain Guard | |

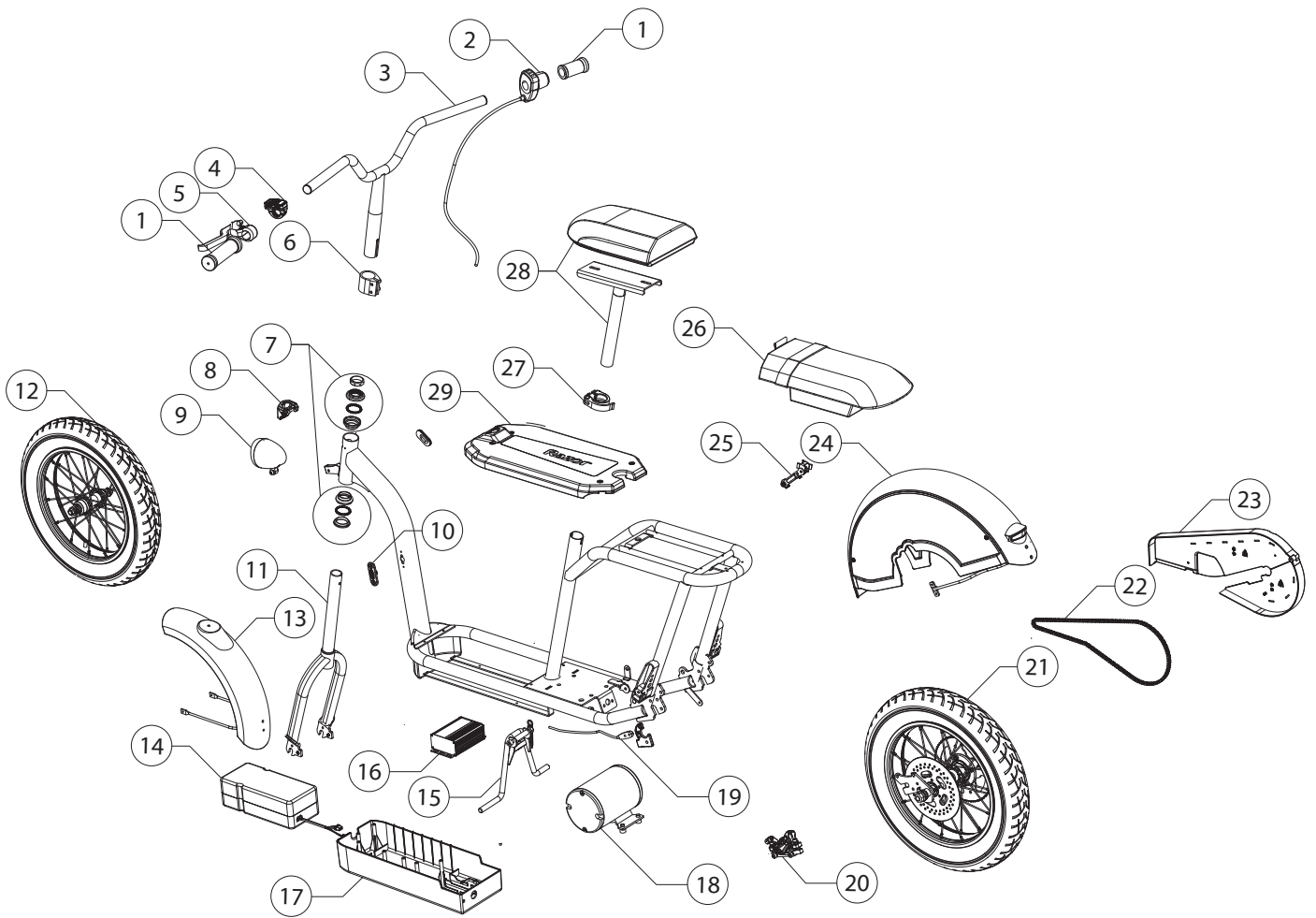

NOTICE: INSURANCE
YOUR INSURANCE POLICIES MAY NOT PROVIDE COVERAGE FOR
ACCIDENTS INVOLVING THE USE OF THIS SCOOTER/ELECTRIC
RIDE-ON PRODUCT. TO DETERMINE IF COVERAGE IS PROVIDED,
YOU SHOULD CONTACT YOUR INSURANCE COMPANY OR AGENT.

FCC COMPLIANCE

This device complies with Part 15 of the FCC Rules. Operation is subject to the following two conditions: (1) This device may not cause harmful interference, and (2) this device must accept any interference received, including interference that may cause undesired operation.

Note: This equipment has been tested and found to comply with the limits for a Class B digital device, pursuant to part 15 of the FCC Rules. These limits are designed to provide reasonable protection against harmful interference in a residential installation. This equipment generates, uses and can radiate radio frequency energy and, if not installed and used in accordance with the instructions, may cause harmful interference to radio communications. However, there is no guarantee that interference will not occur in a particular installation. If this equipment does cause harmful interference to radio or television reception, which can be determined by turning the equipment off and on, the user is encouraged to try to correct the interference by one or more of the following measures:

- Reorient or relocate the receiving antenna.
- Increase the separation between the equipment and receiver.
- Connect the equipment into an outlet on a circuit different from that to which the receiver is connected.
- Consult the dealer or an experienced radio/TV technician for help.

⚠ WARNING: Changes or modifications to this product not expressly approved by Razor USA LLC, could void the user's authority to operate the equipment.

For your records, save your original sales receipt with this manual and write the serial number below.

www.razor.com/mx