



C45™

ADULT ELECTRIC SCOOTER



⚠ NOTE: If using the factory set (default) kick-to-start option, the unit must be traveling at least 3 mph (5 km/h) before motor will engage. Kick to start to at least 3 mph (5 km/h) while applying the throttle to engage motor.

OWNER'S MANUAL

Read and understand this entire manual before using this product!

NOTE: Manual illustrations are for demonstration purposes only. Illustrations may not reflect exact appearance of actual product. Specifications subject to change without notice.

CONTENTS

Safety Warnings.....	1-2	Usage.....	7-9
Before You Begin.....	3	Repair and Maintenance.....	10-11
Assembly and Set-Up.....	4	Troubleshooting Guide.....	12-13
Charging the Battery.....	5		
Pre-Ride Checklist.....	6		

INTRODUCTION: RAZOR C45 ELECTRIC SCOOTER

THE RAZOR C45 IS BASED ON THE LATEST COMMUTER SCOOTERS FOR ADULT USERS AND SHOULD ONLY BE RIDDEN CAREFULLY AND RESPONSIBLY BY APPROPRIATELY MATURE AND RESPONSIBLE RIDERS EXERCISING CAUTION AND RESPECTING APPLICABLE LAWS.

The Razor C45 Scooter is part of a new generation of electric scooter mobility. Razor has years of experience as a leader in motorized scooter technology, and in making access to such technology more useful and appropriately available for mature riders in environments which present desirable opportunities for local travel and commutes – but which also, necessarily and importantly, can present additional levels of risk of accident due to use around cars, pedestrians and public streets.

The Razor C45, therefore, is necessarily both similar to, and in many respects different from, previous scooters. This product is not a toy for young riders! Razor emphasizes, therefore, the importance of riders to understand the risks associated with using literally any wheeled product around vehicle or pedestrian traffic and the specific risks of riding an electric scooter. Bluntly put, you could get hurt and your actions could cause injury to others. You must be cautious, alert and take reasonable precautions to minimize such risks of falls, impacts or other problems.

Generally, the Razor C45 has longer battery life, multiple speed options (Normal Mode up to 10 mph (16 km/h), Cruising Mode up to 15.5 mph (25 km/h) and Sport Mode up to 19.9 mph (32 km/h)), and a more efficient hub motor propulsion system which makes it more amenable to “commute” uses. The user must be, and is, responsible for determining whether local laws permit use of the Razor C45 in varying circumstances (there is no “uniform Federal law” in existence to establish universal riding conditions). The rider must be, and is, responsible for acting maturely, carefully, and with respect for local rules of the road when riding, and the rider must be, and is, responsible for assessing and minimizing effects of potentially adverse riding conditions including darkness or impaired visibility, fog, rain, snow, hail, ice or electrical storms, which increase dangers inherent in operating any scooter. The rider must be, and is, responsible for adjusting riding behavior and braking distance to suit the weather and traffic conditions, and also to recognize that riding in low visibility conditions decreases your ability to see and be seen, especially on public streets and around vehicles or pedestrians. The Razor C45 head- and tail-lights may reduce such risks, and riders also are encouraged to seek to enhance their visibility/conspicuity through use of higher visibility garments, lights or other reflective materials when riding in reduced visibility circumstances. Razor absolutely recommends that any rider wear a proper helmet to minimize potential head injuries.

Use of the Razor C45 scooter is recommended for mature riders -- using age 18+ (the generally recognized age of “legal consent”) as a guide, as do Razor’s Micromobility (rental) Scooters. Riders of the Razor C45 certainly must respect and adhere to all locally applicable laws and rules applicable to the use of such products.

SAFETY WARNINGS

⚠ WARNING: Riding a C45 does present potential risks and caution is required. Like any riding product, a C45 has inherent hazards associated with its use (for example, falling off or riding it into a hazardous situation). Like any riding product, the C45 can and is intended to move and it is therefore, of course, possible to lose control or otherwise get into dangerous situations. Riders must recognize that if such things occur, a rider can be seriously injured or die even when using safety equipment and other precautions. RIDE AT YOUR OWN RISK AND USE COMMON SENSE.

⚠ WARNING: Always check and obey any local laws or regulations which may affect the locations where the C45 may be used. Keeping away from cars and motor vehicle traffic provides the highest protection against risk of traffic-related injuries, of course. For mature riders seeking to operate this product as legally permitted for commuting applications, the increased risks presented by traffic certainly emphasizes that the need for caution, personal responsibility and compliance with local laws is imperative and is the rider’s responsibility. Only use where allowed and with caution.

⚠ WARNING: PARENTAL AND ADULT RESPONSIBILITY AND SUPERVISION IS NECESSARY TO ASSURE USE BY MATURE RIDERS: Because products, like the C45 electric scooter, can and do present potential hazards plainly associated with their use, it is well recognized THE NEED FOR EXERCISE OF PARENTAL RESPONSIBILITY IN SELECTING RIDING PRODUCTS APPROPRIATE TO THE AGE OF A CHILD, OR PARENTAL SUPERVISION IN SITUATIONS IN WHICH CHILDREN OF VARIOUS AGES MAY HAVE ACCESS TO THE SAME RIDING PRODUCTS, IS IMPORTANT. Not every product is appropriate for every age or size of child, and different age recommendations are found within this category of product which are intended to reflect the nature of the hazards and the expected mental or physical ability, or both, of a child to cope with the hazards.

⚠ WARNING: NOT FOR RIDERS UNDER AGE 18 OR HEAVIER THAN 220 LB (100 KG). DO NOT EXCEED THE WEIGHT LIMIT OF 220 lb (100 kg) – including backpacks and other items that might be carried. Exceeding the weight limit could injure the rider and damage the C45. Rider weight alone also does not necessarily mean a person’s size is appropriate to fit or maintain control of the C45. Keep this product away from

SAFETY WARNINGS

small children and remember that this product is not a toy and is intended for use only by persons who are, at a minimum, completely comfortable and competent while operating the product.

Razor recommends that children under the age of 18 not be permitted to use this product. This recommendation is based not just on age or weight or height; it reflects consideration of expected maturity and skills as well as physical size. The recommended rider age of 18 years or older is only an estimate and can be affected by the rider's size, weight, or skills – not every rider 18 years old or older will be suited to the product. Certainly, any rider unable to fit comfortably on the C45 should not attempt to ride it, but **a parent's decision to allow his or her child to ride this product should be based on the child's maturity, skill, and ability to follow rules. Razor emphasizes that adults are strongly advised not to disregard Razor's recommendations or permit younger children to ride the C45.**

Keep this product away from small children and remember that it is intended for use only by persons who are, at a minimum, completely comfortable and competent while operating.

Persons with any mental or physical conditions that may make them susceptible to injury, impair their physical dexterity or mental capabilities to recognize, understand, and follow safety instructions and to be able to understand the hazards inherent in the use of any ride-on product, should not use or be permitted to use products inappropriate for their abilities. Persons with heart conditions, head, back or neck ailments (or prior surgeries to these areas of the body), or pregnant women, should be cautioned not to operate such products.

DO NOT EXCEED THE WEIGHT LIMIT OF 220 lb (100 kg). Rider weight does not necessarily mean a person's size is appropriate to fit or maintain control of the C45.

CHECK AND MAINTAIN PRODUCT CONDITIONS

Before use, check to confirm that covers and guards are in place and in serviceable condition. Check that the brake and lights are functioning properly, that the front tire is inflated properly and has sufficient tread remaining. The product should be maintained and repaired in accordance with the manufacturer's specifications, using only the manufacturer's authorized replacement parts, and should not be modified from the manufacturer's original design and configuration.

ACCEPTABLE RIDING PRACTICES AND CONDITIONS

Do not activate the throttle unless you are on the C45 and in a safe, outdoor environment suitable for riding. **If using the factory set (default) kick-to-start option, the electric scooter must be moving at least 3 mph (5 km/h) before the motor will engage.** Once the throttle is activated the C45 will move forward.

The normal powered top speed of this product will be approximately 19.9 mph (32 km/h), which can be affected by conditions, such as rider weight, inclines and battery charge level. Avoid excessive speeds that can be associated with downhill rides.

Maintain a hold on the handlebars at all times. Do not touch the brake or motor on your scooter when in use or immediately after riding, as these parts can become very hot.

Ride defensively. Watch out for potential obstacles that could catch your wheel or force you to swerve suddenly or lose control. Be careful to avoid pedestrians, skaters, skateboards, scooters, bikes, children or animals who may enter your path, and respect the rights and property of others.

The C45 is intended for use on flat, dry surfaces, such as pavement or level ground, without loose debris, such as sand, leaves, rocks or gravel. Wet, slick, bumpy, uneven or rough surfaces may impair traction and contribute to possible accidents. Do not ride your product in mud, ice, puddles or water. Watch out for potential obstacles that could catch your wheel or force you to swerve suddenly or lose control. Avoid sharp bumps, drainage grates, and sudden surface changes.

Do not attempt to do stunts or tricks. The C45 is not made to withstand abuse from misuse, such as jumping, curb grinding or any other type of stunts. Racing, stunt riding, or other maneuvers also enhance risk of loss of control, or may cause uncontrolled rider actions or reactions.

Never allow more than one person at a time to ride the product.

Riding at night or when visibility is limited increases risks of accident or injury. Should the C45 scooter be ridden in such conditions, use of lights and additional measures to increase rider visibility and scooter conspicuity are advised.

Never use near steps or swimming pools.

The C45 electric scooter can operate more quietly than other motorized products may operate. Use care when in the vicinity of pedestrians or others who may have difficulty hearing your approach. Use handbell (not included) to sound warnings when appropriate.

Do not allow hands, feet, hair, body parts, clothing, or similar articles to come in contact with moving parts or wheels while the motor is engaged.

Do not touch electric motor or brake when in use or immediately after riding.

Never use headphones or a cell phone to talk or text when riding.

Never ride your product while under the influence of drugs or alcohol.

Never hitch a ride with a vehicle.

PROPER RIDING ATTIRE

Always wear proper protective equipment, such as an approved safety helmet (with chin strap securely buckled), elbow pads, and kneepads. A helmet may be legally required by local law or regulation in your area. A long-sleeved shirt, and long pants are recommended. Always wear shoes and keep shoelaces tied and out of the way of the wheels and motor. Never ride barefooted or in sandals.

USING THE CHARGER

The charger supplied with the product should be regularly examined for damage to the cord, plug, enclosure and other parts. In the event of such damage, the product must not be charged until the charger has been repaired or replaced.

Use only with the recommended charger.

Use caution when charging.

The charger is not a toy. Charger should be operated by an adult.

Do not operate charger near flammable materials.

Unplug charger and disconnect from product when not in use.

Always disconnect from the charger prior to wiping down and cleaning your product with damp cloth.

FAILURE TO USE COMMON SENSE AND HEED THE ABOVE WARNINGS FURTHER INCREASES RISK OF SERIOUS INJURY. USE AT YOUR OWN RISK AND WITH APPROPRIATE AND SERIOUS ATTENTION TO SAFE OPERATION. USE CAUTION.

BEFORE YOU BEGIN

Remove contents from box. Remove the separators that protect the components from damage during shipping. Inspect the contents of the box for scratches in the paint, dents that may have occurred during shipping. Because your scooter was partially assembled and packed at the factory, there should not be any problems, even if the box has a few scars or dents.

MAKE SURE POWER SWITCH IS TURNED "OFF" BEFORE CONDUCTING ANY ASSEMBLY OR MAINTENANCE PROCEDURES.

Estimated Assembly and Set-Up Time

Razor recommends assembly by an adult.

Allow up to 15 minutes for assembly, not including initial charge time.

Allow up to 6 hours for charge (see page 5 for charging information).

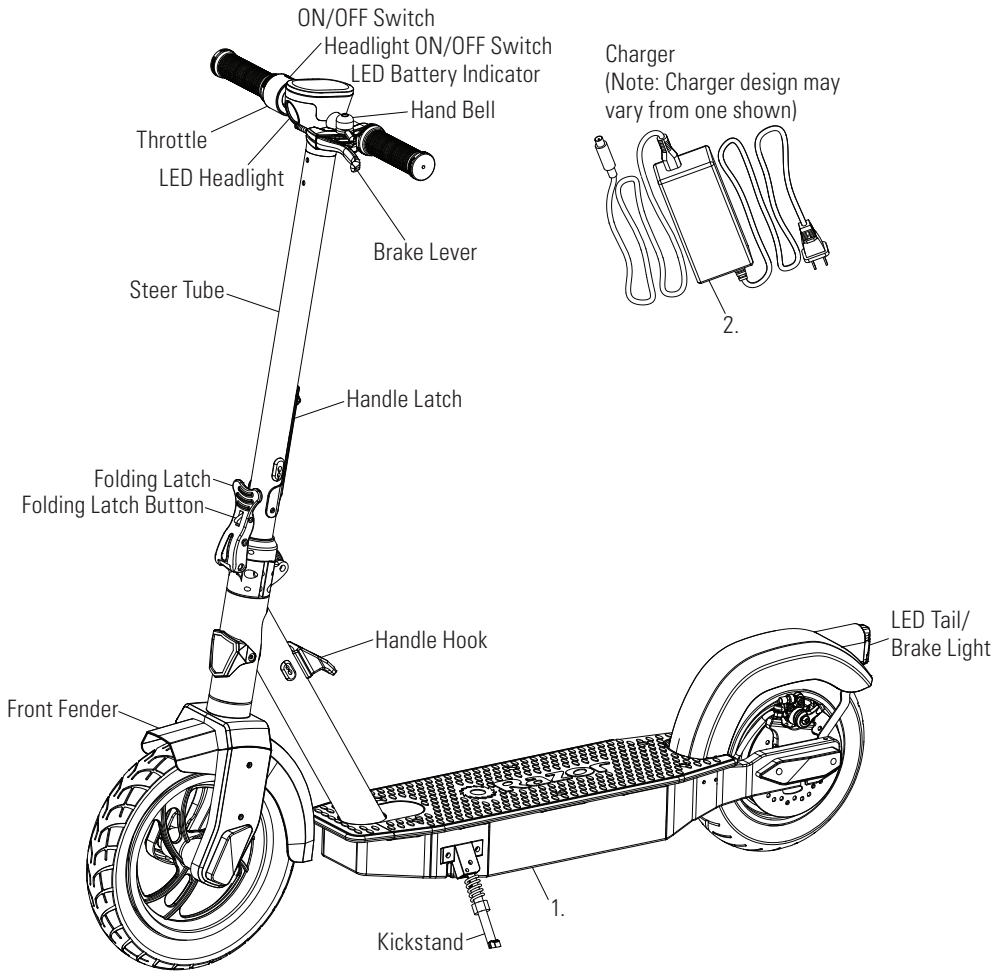

WARNING:
DO NOT USE NON-RAZOR PARTS WITH YOUR RAZOR ELECTRIC SCOOTER. Razor scooters have been built to certain Razor design specifications. The original equipment supplied at the time of sale was selected on the basis of its compatibility with the frame and all other parts. Certain aftermarket components may not be compatible. Use of non-Razor parts will void the warranty.

Note: If using the factory set (default) kick-to-start option, the electric scooter must be moving at least 3 mph (5 km/h) while applying throttle to engage motor.

Product ID Locations:
(See locations to the left)

1. Side of Deck
2. Charger
3. UPC Side of Box (Not Shown)

Required Tools and Parts

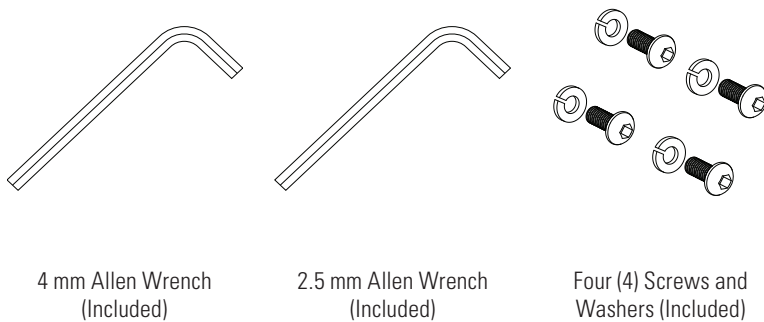

Box Contents:

- C45
- Charger
- Owner's Manual
- Tools and Parts

ASSEMBLY AND SET-UP

□ Unfolding the Scooter for First Time Use

Required Tool: 4 mm Allen Wrench (included)

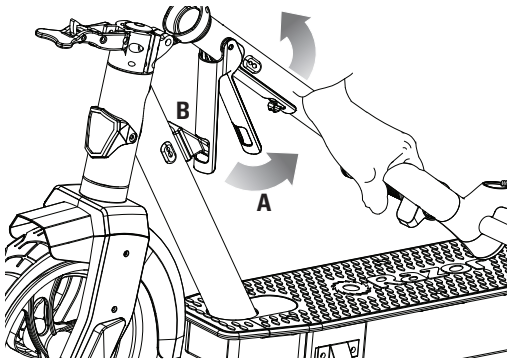

1 To unfold scooter, disengage the Handle Latch (A) from the Handle Hook (B) and stow the Handle Latch against the Steer Tube.

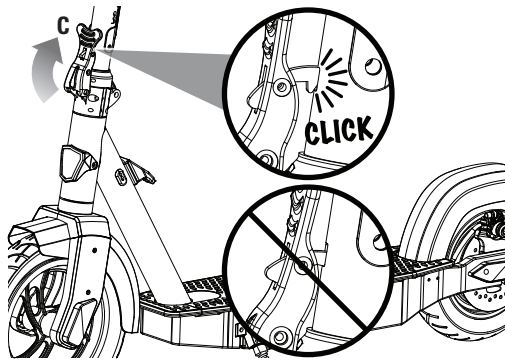

2 With the Steer Tube upright, secure the Folding Latch (C) by pushing open Folding Latch up against the Steer Tube to lock in place. Once secured, pull out on the Folding Latch (C) to test that it's engaged and locked.

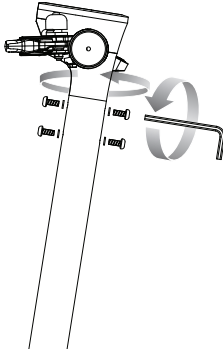

3 Turn the handlebars 90° and tighten the four (4) handlebar screws and washers securely with a 4 mm Allen wrench.

□ Inflating the Front Tire

The front tire is inflated when shipped, but it invariably may lose some pressure between the point of manufacturing and your purchase. **Always inflate tire to the correct PSI before first time use.**

Lower air pressure can result in a shorter ride time.

Periodically check front tire. Reinflate when needed.

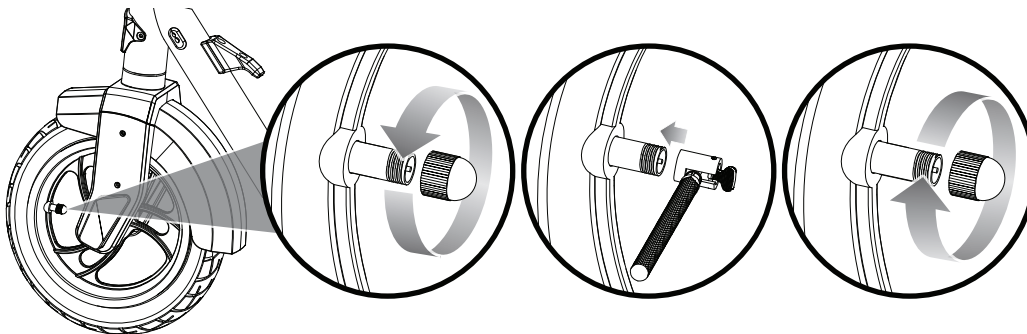

1 Remove the valve cap and using a bicycle style tire pump equipped for a Schrader-type valve, inflate the front tire to the correct PSI indicated on the sidewall of the tire. Replace the valve cap.

⚠ WARNING: Keep fingers clear of the pivoting mechanism when folding or unfolding the scooter. Make sure others are standing clear.

Note: The Folding Latch will make a clicking sound when it is locked into the Steer Tube properly.

⚠ WARNING: Do not use the electric scooter for the first time until you have inflated the front tire to the correct PSI. Failure to do so may damage your electric scooter and void your warranty.

⚠ WARNING: Do not overinflate, as this could damage the tire or wheel.

Note: The pressure air supplies found at gasoline stations are designed to inflate high-volume automobile tires. If you decide to use such an air supply to inflate your electric scooter tire, first make sure the pressure gauge is working, then use very short bursts to inflate to the correct PSI. If you inadvertently overinflate the tire, release the excess pressure immediately.

CHARGING THE BATTERY

Your C45 may not have a fully charged battery; therefore you must charge the battery prior to use. Be sure to charge the battery in a clean, dry location away from direct sunlight, flames or sparks.

- Initial charge time: 6 hours.
- Recharge time: up to 6 hours, even if the light turns green.
- Always charge the battery immediately after riding.
- Fully charge battery before storing for extended periods of time.
- Unplug charger from the wall outlet when not in use.
- Failure to recharge battery periodically may result in a battery that will not accept a charge.
- Make sure the power button is turned OFF when product is not in use. If the power button is left on for an extended period of time, the battery may reach a stage at which it will no longer hold a charge.
- Run time: Up to 70 minutes of continuous ride time. Run time may vary depending on riding conditions, rider weight, climate, and/or proper maintenance.
- Constant starting and stopping may shorten ride time.
- Battery life can vary depending on proper maintenance and usage of the product.
- Do not charge at or below 32°F (0°C).

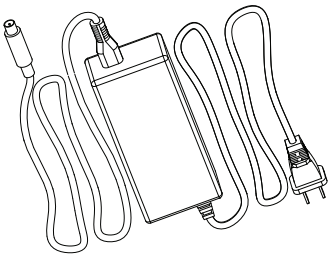

Charger
(Note: Charger design may vary from one shown)

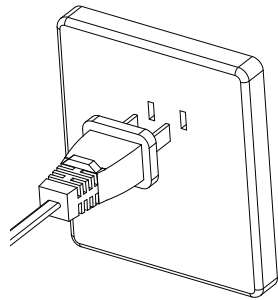

1 Plug the charger plug into wall outlet. The light on the charger should be green.

Note: If green light (LED) does not turn on, try a different outlet.

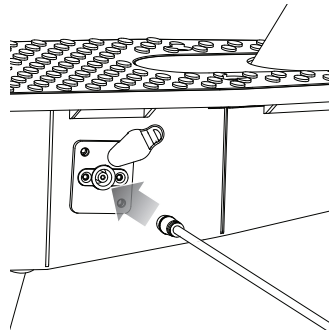

2 Note: Make sure power button is in the **OFF** position. Plug the charger into the charger port. The light on the charger should turn red during charging. The light will turn green again when charging is complete.

⚠ WARNING: Use ONLY with the recommended charger. Batteries are only to be charged under adult supervision. The charger is not a toy. Always disconnect the charger before wiping down and/or cleaning the C45 with a damp cloth.

The charger supplied with the C45 should be regularly examined for damage to the cord, plug, enclosure and other parts. In the event of such damage, the C45 must not be charged until it has been repaired or replaced.

Chargers have built-in overcharge protection to prevent battery from being overcharged.

Note: If the charger gets warm during regular use, this is a normal response and is no cause for concern. If your charger does not get warm during use, it does not mean that it is not working properly.

Wall outlet - Green (stand by)
Wall outlet and unit - Red (charging)
Wall outlet and unit - Green (charged)

Note: Continue charging unit even if light turns green prior to 6 hours.

⚠ WARNING: Battery charge can deplete over time. Periodically recharge battery when not in use.

Model	Voltage (Nominal) Vdc	Capacity (Nominal) Ah	Charge Temperature Range	Operating Temperature Range
C45	46.8	7.6	0° to 40°C 32° to 104°F	-20° to 40°C -4° to 122°F

PRE-RIDE CHECKLIST



Lights

Check the head- and tail-lights for proper function. When you activate the lights (reference "How to Ride" on page 7 of this manual), the headlight and taillight should illuminate.



Brake

Check the brake and brake light for proper function. When you squeeze the brake lever, the brake should provide positive braking action and tail/brake light should illuminate. When you apply the brake with the throttle on/engaged, the brake cut-off switch should cut power to the motor.



Wheels

Periodically inspect the wheels for excessive wear.



Tires

Periodically inspect the tires for excess wear and replace as needed. Regularly check the front tire pressure and inflate as needed.



Frame, Fork and Handlebars

Check for cracks or broken connections. Although broken frames are rare, it is possible for an aggressive rider to run into a curb or object and wreck, bend or break a frame. Get in the habit of inspecting your scooter on a regular basis.



Hardware/Loose Parts

Before every ride, check all parts, such as nuts, bolts, fasteners, etc., to ensure they are secure and assembled correctly. There should not be any unusual rattles or sounds from loose parts or broken components. If the product is damaged, do not ride. **Reference "Safety Warnings" on pages 1 and 2 of this manual.**



Safety Gear

Always wear proper protective equipment, such as an approved safety helmet (with chin strap securely buckled), elbow pads, and kneepads. A helmet may be legally required by local law or regulation in your area. A long-sleeved shirt and long pants are recommended. Always wear shoes and keep shoelaces tied and out of the way of the wheels and drive system. **NEVER RIDE BAREFOOTED OR IN SANDALS.**



Laws and Regulations

Always check and obey any local laws or regulations.



Insurance

Do not assume that your existing insurance policies necessarily provide coverage for electric product use. Check with your insurance company for information regarding insurance.



Storage

Prolonged exposure to UV rays, rain and the elements may damage the enclosure materials, store indoors when not in use.

USAGE

□ How to Ride

Do not activate the thumb throttle unless you are on the C45 and in a safe, outdoor environment suitable for riding.

Put kickstand up.

Press the power button **(A)** for two seconds, the LEDs on the battery display will light up. Press the power button **(A)** for two seconds again to turn the unit off.

Headlight and Taillight: To activate the headlight and taillight the product must be powered **ON**. Press the power button **(A)** once to activate the headlight and taillight. To deactivate the headlight and taillight, press the power button once again.

Get on the scooter and place both hands on the handlebars.

Option 1 - Kick-to-Start Setting (factory default): Kick to start **(B)**, and then press down on the thumb throttle **(C)**.

Option 2 - Throttle Start Setting: Press down on the thumb throttle **(C)**.

Note: If you would like to manually change between kick-to-start setting (factory default) to the thumb-throttle start setting, press the power button quickly five (5) times. The electric scooter will beep (sound) each time the power button is pressed. The start setting is saved when the product is powered OFF, so the same start setting will be in effect when you turn the product back ON. Kick-to-start setting drains less power from the battery.

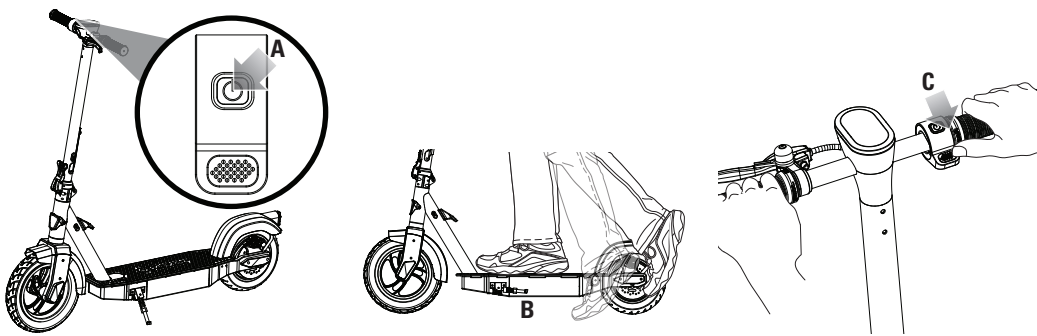

□ How to Stop

For controlled stops, apply the brake by squeezing brake lever **(D)**. Razor recommends that you practice applying the brake at various speeds and in an open area free from obstructions before riding your scooter around others.

When the brake is applied the tail/brake light will glow brighter. The brake light is always functional and independent of the other lights being activated.

Release the thumb throttle **(C)** and squeeze the brake lever **(D)**, the power will cut off and then product will slow to a stop.

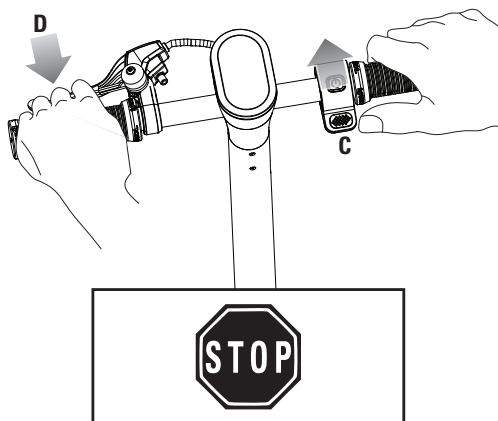

Note: The C45 electric scooter features **Regenerative Braking**. Regenerative braking is a means of recovering and converting kinetic energy into stored power. Using the scooter's electric motor, energy that is usually lost during deceleration and braking is captured and converted back to stored power extending run time and range. Regenerative braking only recovers a small amount of energy at a time but can be significant over the course of a full battery cycle. As always specifications and the amount of recovered regeneration varies with rider weight, terrain, and environmental conditions.

Note: If using the factory set (default) kick-to-start option, the electric scooter must be moving at least 3 mph (5 km/h) while engaging throttle to engage motor.

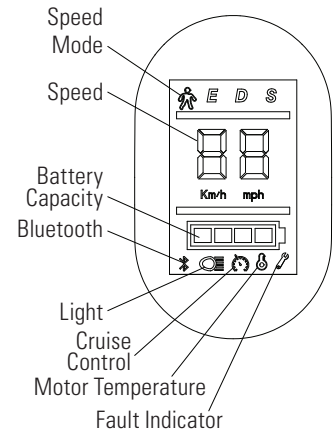

⚠ WARNING: The brake is capable of skidding the rear tire and throwing an unsuspecting rider. Practice in an open area free from obstacles until you are familiar with the brake function. Avoid skidding to a stop as this can cause you to lose control and/or damage the rear tire.

Note: As an additional safety feature, the scooter is designed to cut power to the motor when the brake is applied.

Note: If using the factory set (default) kick-to-start option, the motor will re-engage, (without having to kick to start), if brake is released and throttle is applied **before** scooter has slowed down to **under 3 mph (5 km/h)**.

Note: Practice riding only in wide open areas clear from curbs, parking blocks and other obstacles. Impacting the wheels against any hard surface can damage the wheels. Wheels are not covered under the limited warranty.

USAGE

□ Changing the Speed Mode

There are three modes for speed. The C45 is set on the Sport (19.9 mph (32 km/h)) speed setting at the factory. Press power button twice quickly to select the speed mode.

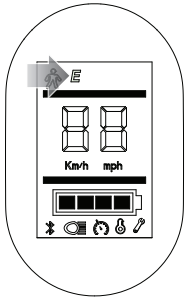

1 The Normal mode max speed is up to 10 mph (16 km/h) as shown by an "E" at the top of the display.

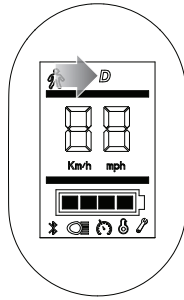

2 The Cruising mode max speed is up to 15.5 mph (25 km/h) as shown by an "D" at the top of the display.

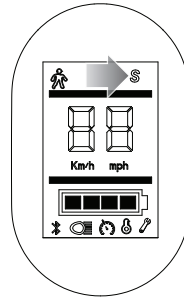

3 The Sport mode max speed is up to 19.9 mph (32 km/h) as shown by an "S" at the top of the display.

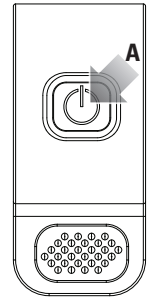

Note: The C45 display default setting is in miles. If you would like to change the display setting to kilometers, press the power button (A) three times quickly to select the kilometers setting.

□ Using and Setting Cruise Control

The C45 electric scooter features **Cruise Control**. While activated, this feature will automatically keep your electric scooter running at a set speed. This allows you to ride without having to constantly press on the thumb throttle. Practice in an open area free from obstacles until you are familiar with the cruise control feature. **Note: The C45 is shipped with the cruise control feature deactivated from the factory.**

□ How to Enable Cruise Control Mode and Set the Speed



1 The cruise control mode is controlled by the power button on the display (A).

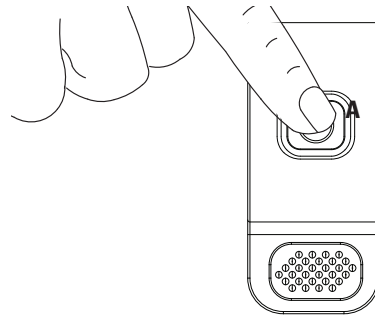

2 While stationary, to enable the cruise control mode, press the power button (A) quickly four (4) times. The electric scooter will then beep (sound) once and the display will illuminate the cruise icon for a few seconds (B).

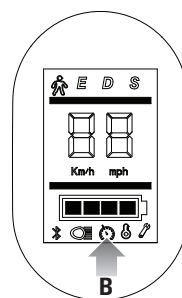
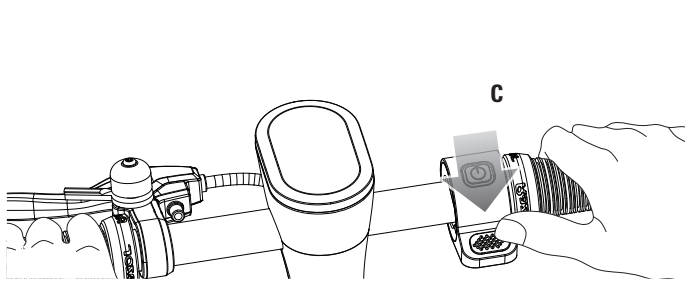
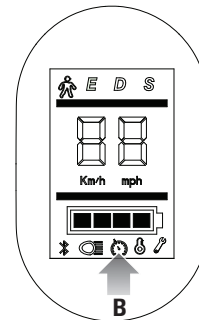

3 The electric scooter must be traveling at least 6 mph (9.7 km/h) to set cruise control speed. To set a constant speed, press the throttle (C) and ride your scooter until you reach your desired speed — then hold the throttle at that speed for eight (8) consecutive seconds. The electric scooter will beep (sound) once and the cruise control icon (B) will appear on the display, indicating that the electric scooter is now set at the desired speed. Once set, you can take your thumb off the throttle and your electric scooter will maintain that set speed. **Using any control such as pressing the throttle or squeezing the brake lever will deactivate the speed setting and the cruise control icon (B) will disappear from the display. Your speed setting will not be saved and you will need repeat step 3 to reset to your desired speed.**

USAGE

❑ How to Disable Cruise Control Mode

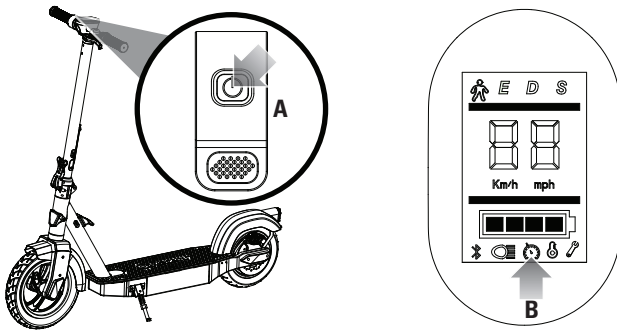

To manually disable the cruise control mode, press the power button (A) quickly four (4) times. The electric scooter will then beep (sound) once and the cruise control icon on the display will turn off (B).

❑ How to Fold Scooter

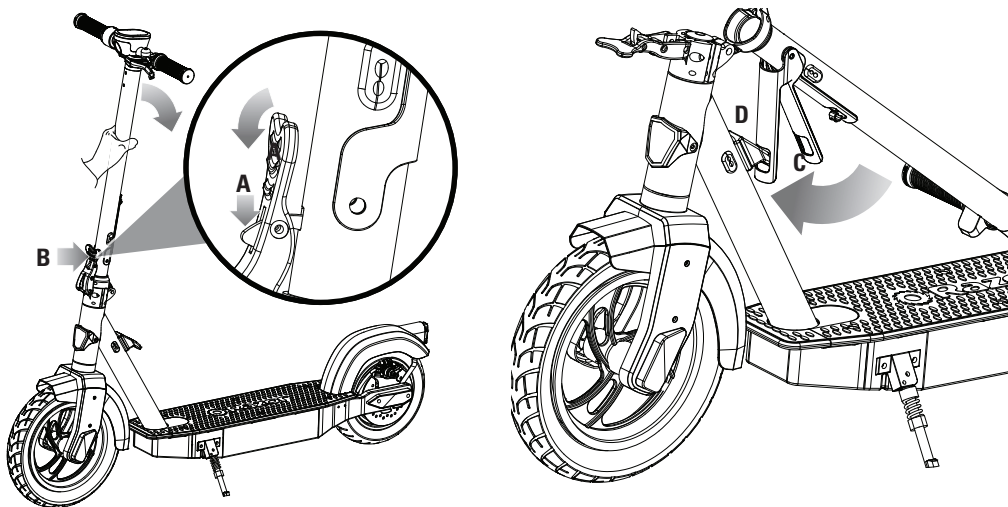

1 To fold scooter, press and hold down the Folding Latch Button (A) while pulling the Folding Latch (B) open.

2 To use the Steer Tube as a carrying handle, deploy the Handle Latch (C) and engage the Handle Hook (D) on the frame.

❑ Downloading the Razor E Rides App



Scan the QR Code on the left to install the Razor E Rides app to your mobile device. Available on iOS and Android app stores. Once the app is installed your electric scooter can be connected to your mobile device via Bluetooth. Downloading the Razor E Rides app allows you to personalize your scooter by taking full control over its settings while tracking trip and speed information while on the go.

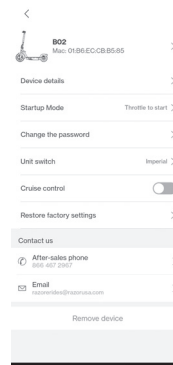
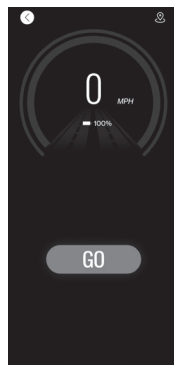
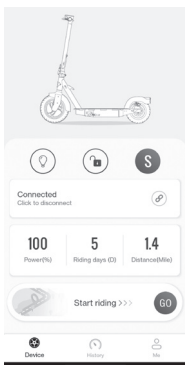

⚠ WARNING: Keep fingers clear of the pivoting mechanism when folding or unfolding the scooter. Make sure others are standing clear.

⚠ WARNING: Do not talk or text on your mobile device while riding. Only change your device's app settings when stationary.

REPAIR AND MAINTENANCE

Turn power switch "OFF" before beginning repair or maintenance:

- Read the instructions
- Secure the product under repair
- Repair and maintenance should be performed by an adult only
- Remove charger plug
- Exercise caution around exposed parts
- Turn the power off

□ Adjusting the Folding Mechanism

Required Tool: 2.5 mm Allen Wrench (included)

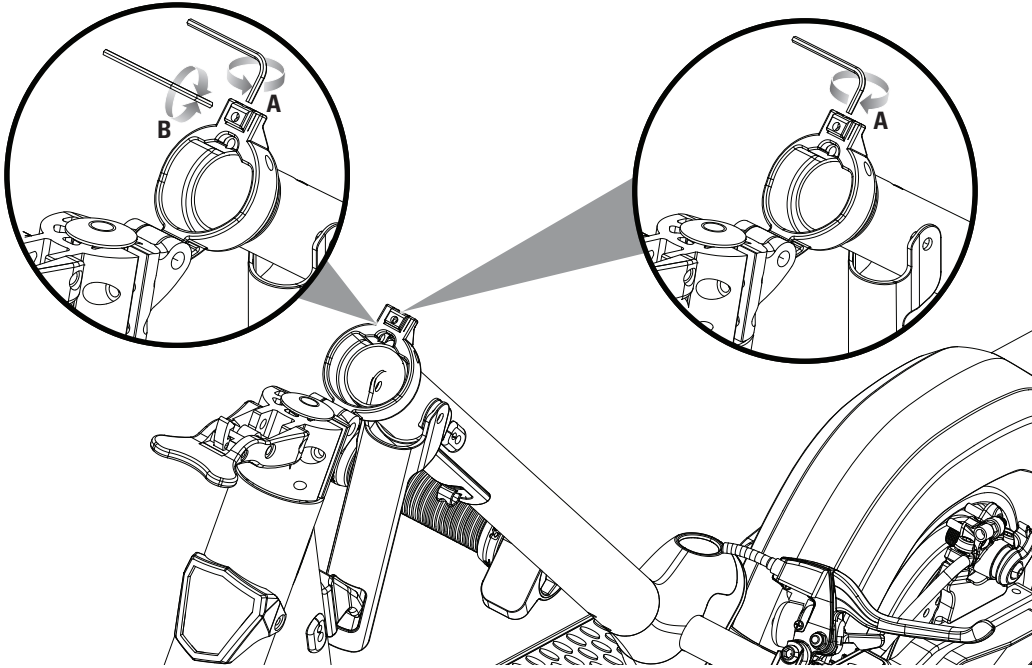

1 Fold scooter according to folding scooter instructions on page 9. Using a 2.5 mm Allen wrench, loosen screw **A**. Using a 2.5 mm Allen wrench adjust screw **B**.

2 Tighten screw **A** and unfold to complete adjustment.

⚠ WARNING: Keep fingers clear of the pivoting mechanism when folding or unfolding the scooter. Make sure others are standing clear.

□ Adjusting the Brake

Required Tool: 5 mm Allen Wrench (not included)

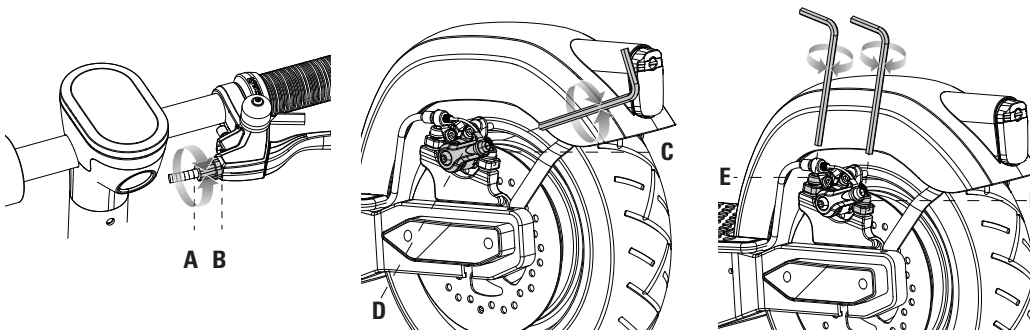

1 Adjusting brake at the brake lever. The best braking distance is when the distance between the brake lever and the grip is 15 mm to 20 mm. Fine tune the brake lever by adjusting screw **(A)** and tighten nut **(B)**.

2 If the brake has too much slack, loosen the screw **(C)** using a 5 mm Allen wrench, pull the brake caliper actuator arm **(D)** while holding the brake cable to the desired tension. Secure the screw **(C)**, test the brake and readjust if needed.

3 If the brake pads are rubbing against the disc brake, loosen screws **(E & F)** using a 5 mm Allen wrench, and line up the brake caliper until the brake pads stop rubbing on the disc brake and retighten the screws **(E & F)**.

REPAIR AND MAINTENANCE

⚠ WARNING: Risk of fire - no user serviceable electric parts.

Cleaning Your Scooter

Wipe with a damp cloth to remove dirt and dust. Do not use industrial cleaners or solvents as they may damage the surfaces. Do not use alcohol, alcohol-based or ammonia-based cleaners as they may damage or dissolve the plastic components or soften the decals or decal adhesive.

Battery Care and Disposal

Do not store in freezing or below freezing temperatures. To properly maintain your battery and ensure maximum battery life, carefully read the "Charging the Battery" section on page 5 of this owner's manual.



CONTAINS LITHIUM-ION BATTERY PACK. BATTERIES MUST BE RECYCLED.

Disposal: Your electric scooter uses a lithium-ion battery pack which must be recycled or disposed of in an environmentally safe manner. Do not dispose of a battery pack in a fire. The battery pack may explode.

Do not dispose of a battery pack in your regular household trash. The incineration, land filling or mixing of batteries with household trash is prohibited by law in most areas. Return exhausted batteries to a federal or state approved lithium-ion battery recycler.

Charger

The charger supplied with the electric scooter should be regularly examined for damage to the cord, plug, enclosure and other parts and in the event of such damage, the product must not be charged until it has been repaired or replaced.

Use **ONLY** with the recommended charger.

Not intended for use at elevations greater than 2000 m above sea level.

Wheels

Wheels and drive system are subject to normal wear and tear. It is the responsibility of the user to periodically inspect wheels for excess wear and replace hub motor components as required.

Recycling Lithium-ion

Batteries: Lithium-ion batteries are recyclable. You can help preserve our environment by returning your used rechargeable batteries to the collection and recycling location nearest you.

TROUBLESHOOTING GUIDE

*Product(s) should be turned **OFF** and fully charged prior to doing any Troubleshooting.

NOTE: All troubleshooting steps should be performed by an adult only.

Problem	Possible Cause	Solution
Does not work out of the box	If using the factory set (default) kick-to-start option, the unit must be traveling at least 3 mph (5 km/h) before motor will engage	Kick to start to at least 3 mph (5 km/h) while engaging throttle to engage motor.
	Undercharged battery	Check lights on charger: Plugged into wall - Green Plugged into wall & unit - Red (charging) Plugged into wall & unit - Green (charging complete) No lights/Blinking lights - Replace charger
No longer works	No lights on charger	Check power to wall outlet and/or try a different outlet.
	Undercharged battery	Check lights on charger: Plugged into wall - Green Plugged into wall & unit - Red (charging) Plugged into wall & unit - Green (charging complete) No lights/Blinking lights - Replace charger
	Battery will not hold a charge	Replace battery.
Short run time/runs slow	Rider's weight	Do not exceed 220 lb (100 kg) maximum weight limit.
	Riding conditions	Use only on flat, dry surfaces. Avoid inclines and areas with heavy debris.
	Battery not fully charged	Charge product - refer to page 5 for charging information. Replace battery.
	Old/damaged battery	Charge battery at least once a month when not in use.

TROUBLESHOOTING GUIDE

In the unlikely event of a problem, the controller can provide diagnostic information according to the codes listed below.

*Product(s) should be turned **OFF** and fully charged prior to doing any Troubleshooting.

NOTE: All shooting steps should be performed by an adult only.

Display Error	Possible Cause	Solution	Note
E1	Bad connection between motor and controller.	Check connectors between the motor and controller.	The motor may be the issue but this is highly unlikely.
E2	Throttle Failure.	Check connections between the throttle and controller.	If connections are correct then throttle needs to be replaced.
E3	Motor issue.	Cycle the throttle or turn the unit OFF, then ON.	It may be necessary to wait for the motor to cool down.
E4	Controller issue.	Replace controller.	
E6	Controller issue.	Check connections between the display and controller.	If connections are correct, the controller needs to be replaced.
E7	Battery issue.	Battery needs to be replaced.	
E8	Motor or controller issue.	Check connections between motor and controller.	If connections are correct then controller needs to be replaced.
E9	Brake issue.	Check connections between the brake and controller.	If connections are correct then brake lever needs to be replaced.

FCC COMPLIANCE

FCC ID: 2AGU6008 IC: 21056-008

This device complies with Part 15 of the FCC Rules. Operation is subject to the following two conditions: (1) This device may not cause harmful interference, and (2) this device must accept any interference received, including interference that may cause undesired operation.

Note: This equipment has been tested and found to comply with the limits for a Class B digital device, pursuant to part 15 of the FCC Rules. These limits are designed to provide reasonable protection against harmful interference in a residential installation. This equipment generates, uses and can radiate radio frequency energy and, if not installed and used in accordance with the instructions, may cause harmful interference to radio communications. However, there is no guarantee that interference will not occur in a particular installation. If this equipment does cause harmful interference to radio or television reception, which can be determined by turning the equipment off and on, the user is encouraged to try to correct the interference by one or more of the following measures:

- Reorient or relocate the receiving antenna.
- Increase the separation between the equipment and receiver.
- Connect the equipment into an outlet on a circuit different from that to which the receiver is connected.
- Consult the dealer or an experienced radio/TV technician for help.

⚠ WARNING: Changes or modifications to this unit not expressly approved by Razor USA, could void the user's authority to operate the equipment.

For your records, save your original sales receipt with this manual and write the serial number below.

NOTICE: INSURANCE
YOUR INSURANCE POLICIES MAY NOT PROVIDE COVERAGE FOR
ACCIDENTS INVOLVING THE USE OF THIS SCOOTER/ELECTRIC
RIDE-ON PRODUCT. TO DETERMINE IF COVERAGE IS PROVIDED,
YOU SHOULD CONTACT YOUR INSURANCE COMPANY OR AGENT.

www.razor.com/mx