



# rambler 16<sup>TM</sup>

## ELECTRIC MINI-BIKE



# OWNER'S MANUAL

**Read and understand this entire manual before using this product!**

**NOTE: Manual illustrations are for demonstration purposes only.  
Illustrations may not reflect exact appearance of actual product.  
Specifications subject to change without notice.**

Las garantías de Razor no son válidas para productos comprados fuera de USA. Consulte con su distribuidor las políticas de la garantía. Para piezas y otra información relacionada con el producto, visite:

[www.razor.com/mx](http://www.razor.com/mx)

Hecho en China

# CONTENTS

Safety Warnings.....	1-2	Repair and Maintenance.....	7-10
Before You Begin.....	3	Troubleshooting Guide.....	11
Assembly and Set-Up.....	4-5	Rambler 16 Parts.....	12
Charging the Battery.....	5		
Pre-Ride Checklist.....	6		
Usage.....	7		

## SAFETY WARNINGS

**⚠ WARNING:** Riding a Rambler 16 does present potential risks and caution is required. Like any riding product, a Rambler 16 has inherent hazards associated with its use (for example, falling off or riding it into a hazardous situation). Like any riding product, the Rambler 16 can and is intended to move and it is therefore, of course, possible to lose control or otherwise get into dangerous situations. Riders must recognize that if such things occur, a rider can be seriously injured or die even when using safety equipment and other precautions. **RIDE AT YOUR OWN RISK AND USE COMMON SENSE.**

**⚠ WARNING:** Always check and obey any local laws or regulations which may affect the locations where the Rambler 16 may be used. Keeping away from cars and motor vehicle traffic provides the highest protection against risk of traffic-related injuries, of course. For mature riders seeking to operate this product as legally permitted for commuting applications, the increased risks presented by traffic certainly emphasizes that the need for caution, personal responsibility and compliance with local laws is imperative and is the rider's responsibility. Only use where allowed and with caution.

**⚠ WARNING: PARENTAL AND ADULT RESPONSIBILITY AND SUPERVISION IS NECESSARY TO ASSURE USE BY MATURE RIDERS:** Because products, like the Rambler 16, can and do present potential hazards plainly associated with their use, it is well recognized THE NEED FOR EXERCISE OF PARENTAL RESPONSIBILITY IN SELECTING RIDING PRODUCTS APPROPRIATE TO THE AGE OF A CHILD, OR PARENTAL SUPERVISION IN SITUATIONS IN WHICH CHILDREN OF VARIOUS AGES MAY HAVE ACCESS TO THE SAME RIDING PRODUCTS, IS IMPORTANT. Not every product is appropriate for every age or size of child, and different age recommendations are found within this category of product which are intended to reflect the nature of the hazards and the expected mental or physical ability, or both, of a child to cope with the hazards.

**⚠ WARNING: NOT FOR RIDERS UNDER AGE 18 OR HEAVIER THAN 220 LB (100 KG).** DO NOT EXCEED THE WEIGHT LIMIT OF 220 lb (100 kg) – including backpacks and other items that might be carried. Exceeding the weight limit could injure the rider and damage the Rambler 16. Rider weight alone also does not necessarily mean a person's size is appropriate to fit or maintain control of the Rambler 16. Keep this product away from small children and remember that this product is not a toy and is intended for use only by persons who are, at a minimum, completely comfortable and competent while operating the product.

Razor recommends that children under the age of 18 not be permitted to use this product. This recommendation is based not just on age or weight or height; it reflects consideration of expected maturity and skills as well as physical size. The recommended rider age of 18 years or older is only an estimate and can be affected by the rider's size, weight, or skills – not every rider 18 years old or older will be suited to the product. Certainly, any rider unable to fit comfortably on the Rambler 16 should not attempt to ride it, but **a parent's decision to allow his or her child to ride this product should be based on the child's maturity, skill, and ability to follow rules. Razor emphasizes that adults are strongly advised not to disregard Razor's recommendations or permit younger children to ride the Rambler 16.**

**Keep this product away from small children and remember that it is intended for use only by persons who are, at a minimum, completely comfortable and competent while operating the Rambler 16.**

Persons with any mental or physical conditions that may make them susceptible to injury, impair their physical dexterity or mental capabilities to recognize, understand, and follow safety instructions and to be able to understand the hazards inherent in the use of any ride-on product, should not use or be permitted to use products inappropriate for their abilities. Persons with heart conditions, head, back or neck ailments (or prior surgeries to these areas of the body), or pregnant women, should be cautioned not to operate the Rambler 16.

**DO NOT EXCEED THE WEIGHT LIMIT OF 220 lb (100 kg). Rider weight does not necessarily mean a person's size is appropriate to fit or maintain control of the Rambler 16.**

### CHECK AND MAINTAIN PRODUCT CONDITIONS

Before use, check to confirm that covers and guards are in place and in serviceable condition. Check that the brake and lights are functioning properly, that the tires are inflated properly and have sufficient tread remaining. The product should be maintained and repaired in accordance with the manufacturer's specifications, using only the manufacturer's authorized replacement parts, and should not be modified from the manufacturer's original design and configuration.

### ACCEPTABLE RIDING PRACTICES AND CONDITIONS

Do not activate the throttle unless you are on the Rambler 16 and in a safe, outdoor environment suitable for riding. Once the throttle is activated the Rambler 16 will move forward.

The normal powered top speed of this product will be approximately 15.5 mph (25 km/h), which can be affected by conditions, such as rider weight, inclines and battery charge level. Avoid excessive speeds that can be associated with downhill rides.

Maintain a hold on the handlebars at all times. Do not touch the brake or motor on your Rambler 16 when in use or immediately after riding, as these parts can become very hot.

Ride defensively. Watch out for potential obstacles that could catch your wheel or force you to swerve suddenly or lose control. Be careful to avoid pedestrians, skaters, skateboards, scooters, bikes, children or animals who may enter your path, and respect the rights and property of others.

The Rambler 16 is intended for use on flat, dry surfaces, such as pavement or level ground, without loose debris, such as sand, leaves, rocks or gravel. Wet, slick, bumpy, uneven or rough surfaces may impair traction and contribute to possible accidents. Do not ride your product in mud, ice, puddles or water. Watch out for potential obstacles that could catch your wheel or force you to swerve suddenly or lose control. Avoid sharp bumps, drainage grates, and sudden surface changes.

Do not attempt or do stunts or tricks on the Rambler 16. The Rambler 16 is not made to withstand abuse from misuse, such as jumping, curb grinding or any other type of stunts. Racing, stunt riding, or other maneuvers also enhance risk of loss of control, or may cause uncontrolled rider actions or reactions.

# SAFETY WARNINGS

Never allow more than one person at a time to ride the product.

Riding at night or when visibility is limited increases risks of accident or injury. Should the Rambler 16 be ridden in such conditions, use of lights and additional measures to increase rider visibility and Rambler 16 conspicuity are advised.

Never use near steps or swimming pools.

The Rambler 16 can operate more quietly than other motorized products may operate. Use care when in the vicinity of pedestrians or others who may have difficulty hearing your approach. Use handbell (not included) to sound warnings when appropriate.

Do not allow hands, feet, hair, body parts, clothing, or similar articles to come in contact with moving parts or wheels while the motor is engaged.

Do not touch electric motor or brake when in use or immediately after riding.

Never use headphones or a cell phone to talk or text when riding.

**Never ride your product while under the influence of drugs or alcohol.**

Never hitch a ride with a vehicle.

## PROPER RIDING ATTIRE

Always wear proper protective equipment, such as an approved safety helmet (with chin strap securely buckled), elbow pads, and kneepads. A helmet may be legally required by local law or regulation in your area. A long-sleeved shirt, and long pants are recommended. Always wear shoes and keep shoelaces tied and out of the way of the wheels and motor. Never ride barefooted or in sandals.

## USING THE CHARGER

The charger supplied with the product should be regularly examined for damage to the cord, plug, enclosure and other parts. In the event of such damage, the product must not be charged until the charger has been repaired or replaced.

Use only with the recommended charger.

Use caution when charging.

The charger is not a toy. Charger should be operated by an adult.

Do not operate charger near flammable materials.

Unplug charger and disconnect from product when not in use.

Always disconnect from the charger prior to wiping down and cleaning your product with damp cloth.

**FAILURE TO USE COMMON SENSE AND HEED THE ABOVE WARNINGS FURTHER INCREASES RISK OF SERIOUS INJURY. USE AT YOUR OWN RISK AND WITH APPROPRIATE AND SERIOUS ATTENTION TO SAFE OPERATION. USE CAUTION.**

# BEFORE YOU BEGIN

Remove contents from box. Remove the separators that protect the components from damage during shipping. Inspect the contents of the box for scratches in the paint, dents that may have occurred during shipping. Because your Rambler 16 was partially assembled and packed at the factory, there should not be any problems, even if the box has a few scars or dents.

**MAKE SURE POWER SWITCH IS TURNED "OFF" BEFORE CONDUCTING ANY ASSEMBLY OR MAINTENANCE PROCEDURES.**

## Estimated Assembly and Set-Up Time

Razor recommends assembly by an adult.

Allow up to 15 minutes for assembly, not including initial charge time.

Allow up to 12 hours for charge (see page 5 for charging information).

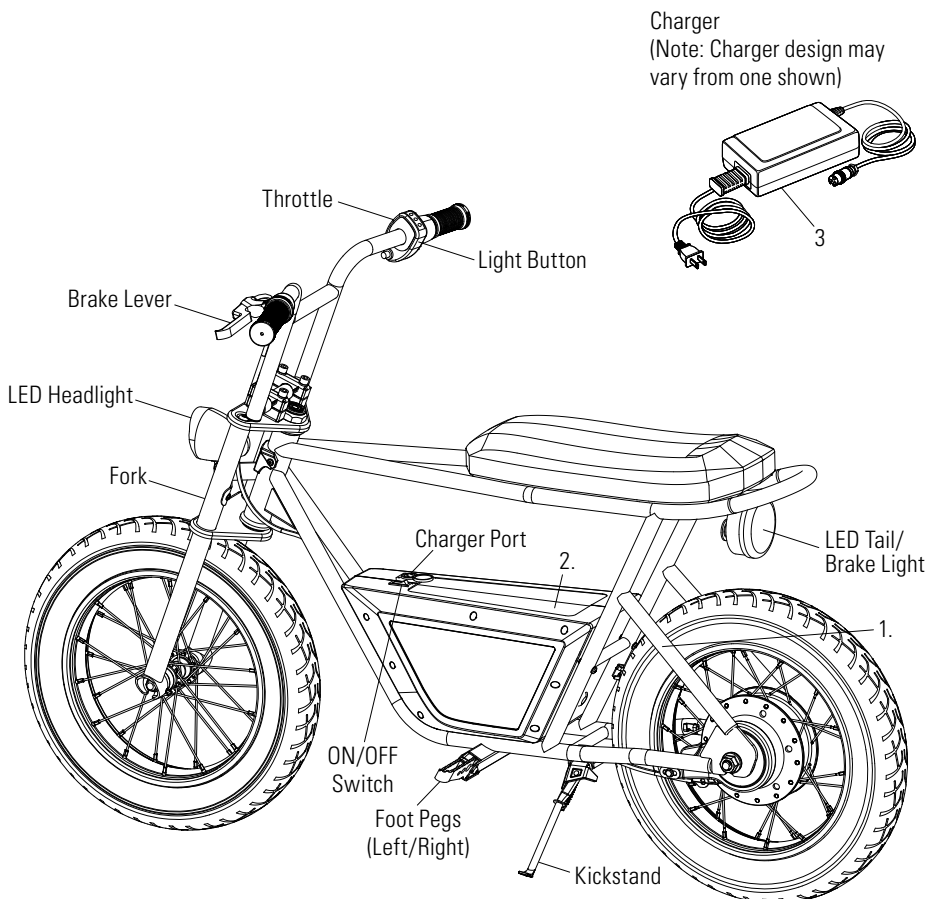

## WARNING:

**DO NOT USE NON-RAZOR PARTS WITH YOUR RAZOR RAMBLER 16.** The Rambler 16 has been built to certain Razor design specifications. The original equipment supplied at the time of sale was selected on the basis of its compatibility with the frame and all other parts. Certain aftermarket components may not be compatible.

## Product ID Locations:

(See locations to the left)

1. Frame
2. Battery Cover
3. Charger
4. UPC Side of Box (Not Shown)

## Required Tools and Parts

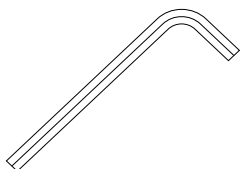

6 mm Allen Wrench  
(Included)

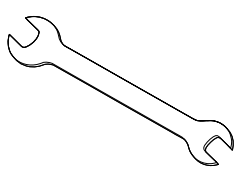

8/10 mm Wrench  
(Included)

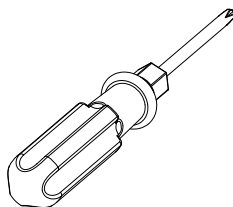

Phillips Screwdriver  
(Not included)

## Box Contents:

- Rambler 16
- Charger
- Owner's Manual
- Tools

# ASSEMBLY AND SET-UP

## □ Attaching the Handlebars

**Required Tool:** 6 mm Allen wrench (included)

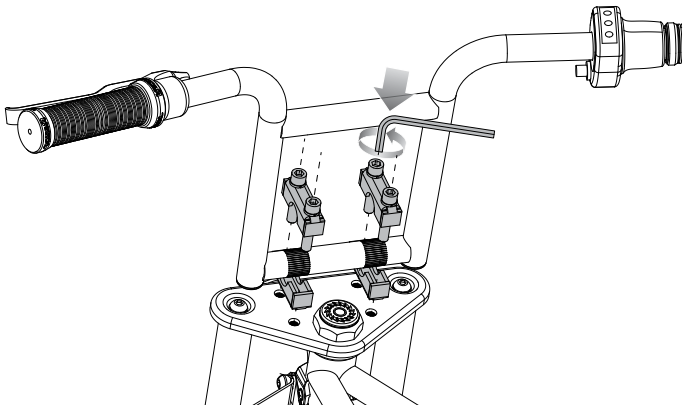

Place the handlebars in the handlebar clamps. Align parallel to the fork and tighten the bolts using a 6 mm Allen wrench. When properly tightened, the handlebars should not move forward or backward.

## □ Attaching the Seat

**Required Tool:** 10 mm Wrench (included)

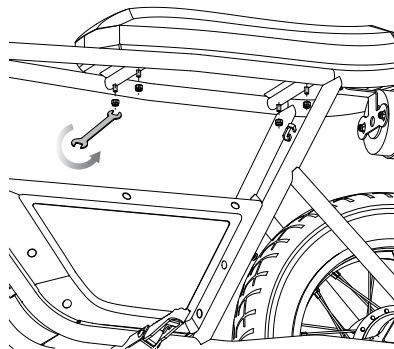
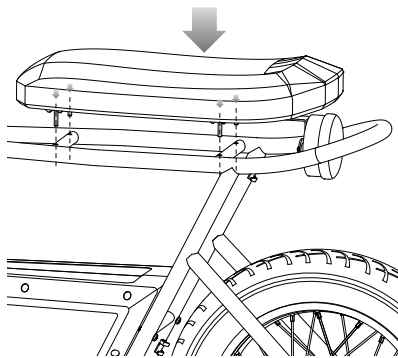

**1** Put the seat on the frame. Note: The four (4) threaded columns at the bottom of the seat need to align with the screw holes in the frame.

**2** Tighten the four (4) lock nuts with an 10 mm wrench to secure the seat to the frame.

## □ Inflating the Tires

The tires are inflated when shipped, but they invariably may lose some pressure between the point of manufacturing and your purchase. **Always inflate tires to the correct PSI before first time use.**

Lower air pressure can result in a shorter ride time.

Periodically check tires. Reinflate when needed.

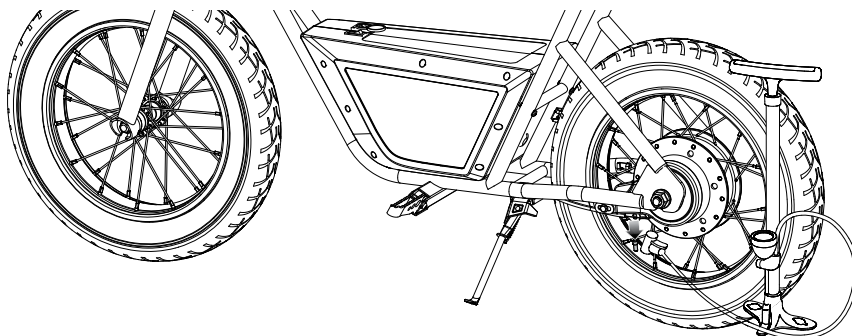

Remove the valve cap and using a bicycle style tire pump equipped for a Schrader-type valve, inflate the tires to the correct PSI indicated on the sidewall of the tires. Replace the valve cap.

**⚠ WARNING:** Do not use the Rambler 16 for the first time until you have inflated the tires to the correct PSI.

**⚠ WARNING:** Do not overinflate, as this could damage the tires or wheels.

**Note:** The pressure air supplies found at gasoline stations are designed to inflate high-volume automobile tires. If you decide to use such an air supply to inflate your Rambler 16 tires, first make sure the pressure gauge is working, then use very short bursts to inflate to the correct PSI. If you inadvertently overinflate the tires, release the excess pressure immediately.

# CHARGING THE BATTERY

**Your Rambler 16 may not have a fully charged battery; therefore you must charge the battery prior to use. Be sure to charge the battery in a clean, dry location away from direct sunlight, flames or sparks.**

- Initial charge time: 12 hours.
- Recharge time: up to 8 hours, even if the light turns green. Recommended maximum charging time is 24 hours.
- Always charge the battery immediately after riding.
- Fully charge battery before storing for extended periods of time.
- Unplug charger from the wall outlet when not in use.
- Failure to recharge battery periodically may result in a battery that will not accept a charge.
- Make sure the power switch is turned OFF when product is not in use. If the power switch is left on for

an extended period of time, the battery may reach a stage at which it will no longer hold a charge.

- To ensure long battery life, never store the product in freezing or below freezing temperatures! Freezing will permanently damage the battery.
- Run time: Up to 45 minutes of continuous ride time. Run time may vary depending on riding conditions, rider weight, climate, and/or proper maintenance.
- Constant starting and stopping may shorten ride time.
- Battery life can vary depending on proper maintenance and usage of the product.
- Do not charge at or below 32°F (0°C).

Charger

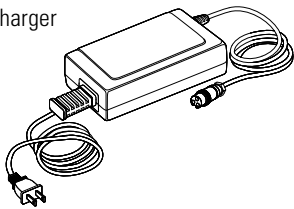

Charger  
(Note: Charger design may vary from one shown)

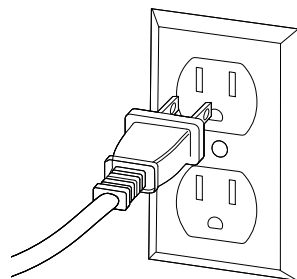

**1** Plug the charger plug into wall outlet. The light on the charger should be green.

**Note:** If green light (LED) does not turn on, try a different outlet.

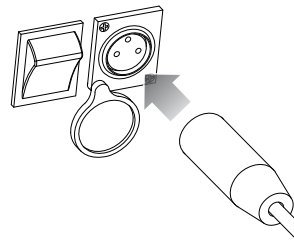

**2 Note:** Make sure power switch is in the **OFF** position. Plug the charger into the charger port. The light on the charger should turn red during charging. The light will turn green again when charging is complete.

**⚠ WARNING:** Use **ONLY** with the recommended charger. Batteries are only to be charged under adult supervision. The charger is not a toy. Always disconnect the charger before wiping down and/or cleaning the Rambler 16 with a damp cloth.

The charger supplied with the Rambler 16 should be regularly examined for damage to the cord, plug, enclosure and other parts. In the event of such damage, the Rambler 16 must not be charged until it has been repaired or replaced.

Chargers have built-in overcharge protection to prevent battery from being overcharged.

**Note:** If the charger gets warm during regular use, this is a normal response and is no cause for concern. If your charger does not get warm during use, it does not mean that it is not working properly.

Wall outlet - Green (stand by)  
Wall outlet and unit - Red (charging)  
Wall outlet and unit - Green (charged)

**Note:** Continue charging unit even if light turns green prior to 8 hours.

**⚠ WARNING:** Battery charge can deplete over time. Periodically recharge battery when not in use.

Model	Voltage (Nominal) Vdc	Capacity (Nominal) Ah	Charge Temperature Range	Operating Temperature Range
Rambler 16	36	7	-10° to 40°C 14° to 104°F	-10° to 40°C 14° to 104°F

## PRE-RIDE CHECKLIST



### Lights

Check the head- and tail-lights for proper function. When you activate the lights (reference "Usage" on page 6 of this manual), the headlight and taillight should illuminate.



### Brake

Check the brake and brake light for proper function. When you squeeze the brake lever (on handlebar) the brake should provide positive braking action and tail/brake light should illuminate. When you apply the brake with the throttle on/engaged, the brake cut-off switch should cut power to the motor.



### Wheels

Periodically inspect the wheels for excessive wear.



### Tires

Periodically inspect the tires for excess wear and replace as needed. Regularly check the tire pressure and inflate as needed.



### Frame, Fork and Handlebars

Check for cracks or broken connections. Although broken frames are rare, it is possible for an aggressive rider to run into a curb or object and wreck, bend or break a frame. Get in the habit of inspecting your Rambler 16 on a regular basis.



### Hardware/Loose Parts

Before every ride, check all parts, such as nuts, bolts, fasteners, etc., to ensure they are secure and assembled correctly. There should not be any unusual rattles or sounds from loose parts or broken components. If the product is damaged, do not ride. **Reference "Safety Warnings" on pages 1 and 2 of this manual.**



### Safety Gear

Always wear proper protective equipment, such as an approved safety helmet (with chin strap securely buckled), elbow pads, and kneepads. A helmet may be legally required by local law or regulation in your area. A long-sleeved shirt and long pants are recommended. Always wear shoes and keep shoelaces tied and out of the way of the wheels and drive system. **NEVER RIDE BAREFOOTED OR IN SANDALS.**



### Laws and Regulations

Always check and obey any local laws or regulations.



### Insurance

Do not assume that your existing insurance policies necessarily provide coverage for electric product use. Check with your insurance company for information regarding insurance.



### Storage

Prolonged exposure to UV rays, rain and the elements may damage the enclosure materials, store indoors when not in use.

## USAGE

### How to Ride

**Do not activate the twist-grip throttle unless you are on the Rambler 16 and in a safe, outdoor environment suitable for riding.**

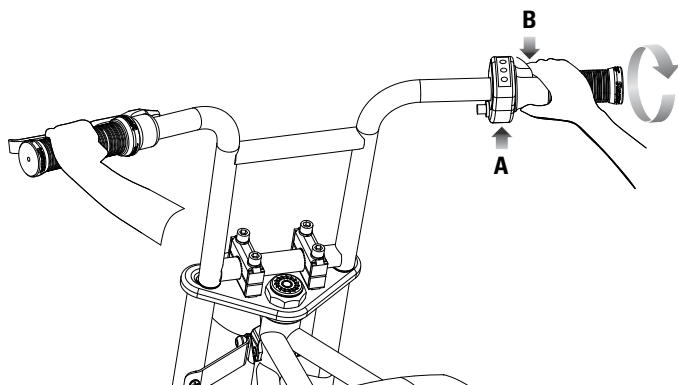

**1** Put kickstand up.

**2** Sit on the Rambler 16 with both feet on the ground to balance the product. Press power switch to **ON** position. Place both hands on the handlebars. Slowly push forward with one foot and twist the throttle (**B**).

**Note:** Keep both feet on the foot pegs when unit is in motion.

**Headlight and Taillight:** To activate the headlight and taillight the product must be powered ON. Press the light button (**A**) once to activate the headlight and taillight. To deactivate the headlight and taillight, press the light button (**A**) again.

# USAGE

## □ How to Stop

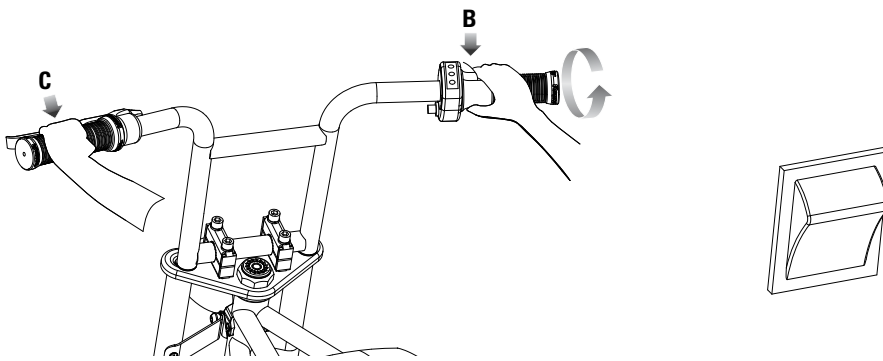

To stop, release the throttle (**B**) and apply the brake, by squeezing the brake lever (**C**), until the product comes to a complete stop. **Note:** When coming to a complete stop, place both feet on the ground to balance the Rambler 16.

**Note:** When the brake is applied the tail/brake light will glow brighter. The brake light is always functional and independent of the other lights being activated.

**Note:** Make sure to turn the product **OFF** after your ride is complete. Pressing the power switch will turn the product **OFF** completely.

**⚠ WARNING:** The brake is capable of skidding the rear tire and throwing an unsuspecting rider. Practice in an open area free from obstacles until you are familiar with the brake function. Avoid skidding to a stop as this can cause you to lose control and/or damage the rear tire.

**Note:** As an additional safety feature, the Rambler 16 is designed to cut power to the motor when the brake is applied.

**Note:** Practice riding only in wide open areas clear from curbs, parking blocks and other obstacles. Impacting the wheels against any hard surface can damage the wheels. Wheels are not covered under the limited warranty.

# REPAIR AND MAINTENANCE

## Turn power switch "OFF" before beginning repair or maintenance:

- Read the instructions
- Remove charger plug
- Turn the power off
- Secure the product under repair
- Exercise caution around exposed parts
- Contact Razor customer service if unsure about any repair or maintenance
- Repair and maintenance should be performed by an adult only

## □ Testing the Brake

To use the brake, squeeze the brake lever to increase the pressure on the brake. The brake lever is fitted with a cable adjuster to compensate for cable stretch and/or to fine-tune the lever movement to engage the brake. If brake is not engaging properly, follow instructions for adjusting the brake outlined below.

## □ Adjusting the Brake

**Required Tool:** 10 mm Wrench (included)

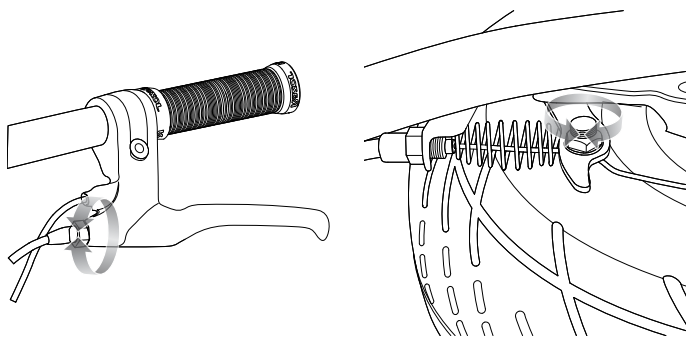

**1** To adjust the tension, thread the brake lever adjuster in or out 1/4 to 1/2 turn until the desired brake adjustment is attained. Most adjustments are complete at this step. If brake still needs further adjustment, proceed to step 2.

**2** If the brake has too much slack, use a 10 mm wrench to loosen the brake anchor cable for additional adjustment and retighten.

**⚠ WARNING:** The brake is capable of causing the electric mini-bike to skid the tire, throwing an unsuspecting rider. Practice in an open area free from obstacles until you are familiar with the brake function. Avoid skidding to a stop as this can cause you to lose control or damage the rear tire.

**Note:** The brake lever contains a safety switch to cut power to the motor when the brake is applied. In an emergency, applying the brake will always stop the product from moving. Do not disable or replace this lever with anything other than a genuine Razor replacement part.



# REPAIR AND MAINTENANCE

## □ Replacing the Battery

**Required Tools:** Phillips Screwdriver (not included) and 4 mm Allen Wrench (included)

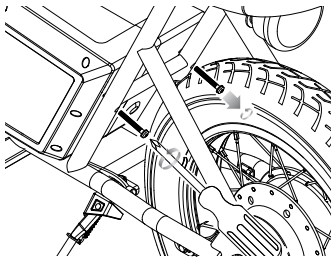

**1** Using a Phillips screwdriver remove the two (2) screws at the back of the battery box.

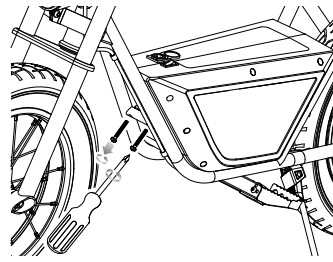

**2** Using a Phillips screwdriver remove the two (2) screws at the front of the battery box.

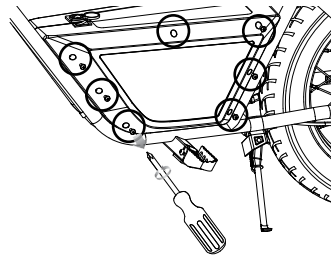

**3** Using a Phillips screwdriver remove the seven (7) screws from the side of the battery box.

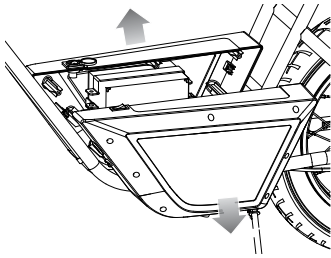

**4** Remove the battery box

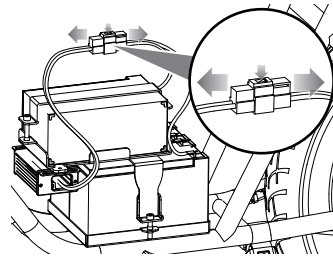

**5** Unplug the power cord connector.

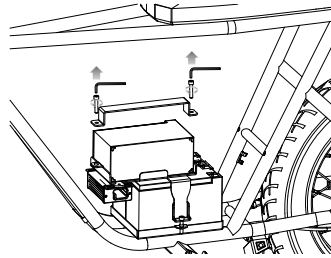

**6** Using a 4 mm Allen wrench, remove the two (2) screws from the top of the battery bracket (upper).

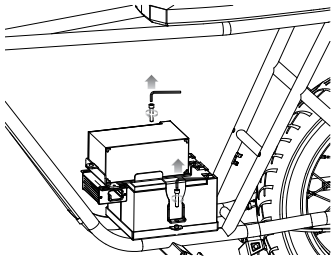

**7** Using a 4 mm Allen wrench, remove the two (2) screws from the sides where the battery is attached to the battery bracket (lower).

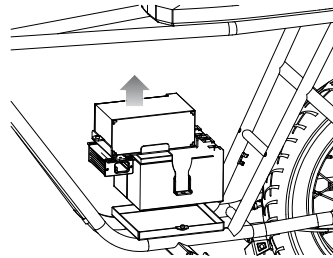

**8** Remove the battery bracket (lower) and battery.

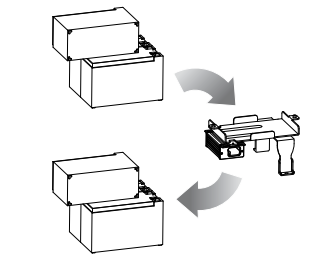

**9** Replace with new battery.

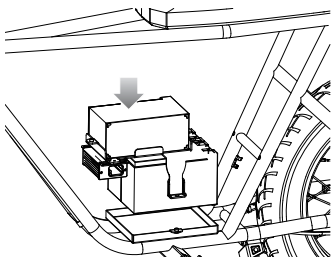

**10** Put the battery bracket (lower) and battery back onto the frame.

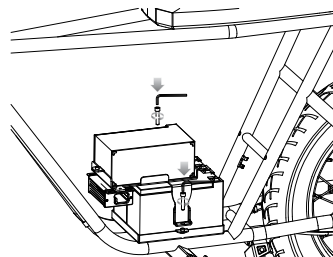

**11** Using a 4 mm Allen wrench, replace the two (2) screws at the sides where the battery is attached to the battery bracket (lower).

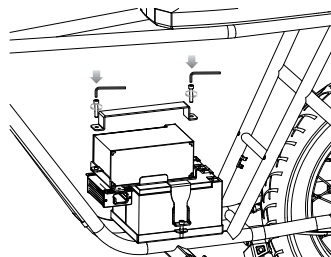

**12** Using a 4 mm Allen wrench, replace the two (2) screws at the top of the battery bracket (upper).

# REPAIR AND MAINTENANCE

## □ Replacing the Battery Continued

**Required Tools:** Phillips Screwdriver (not included) and 4 mm Allen Wrench (included)

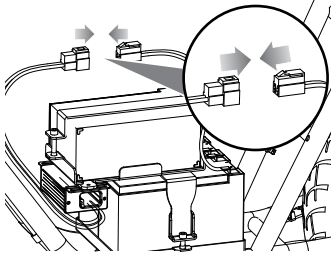

**13** Plug in the power cord connector.

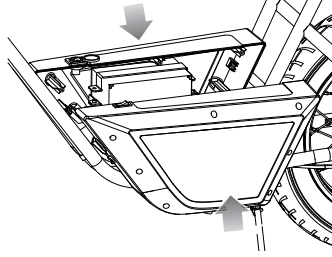

**14** Replace the battery box.

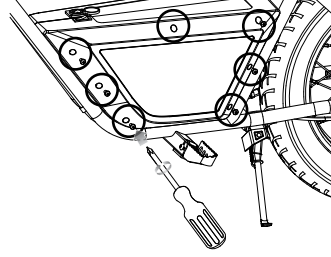

**15** Using a Phillips screwdriver replace the seven (7) screws at the side of the battery box.

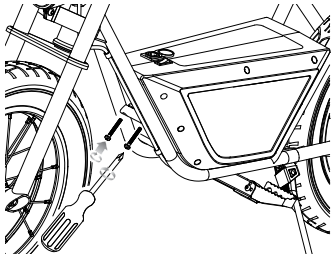

**16** Using a Phillips screwdriver replace the two (2) screws at the front of the battery box.

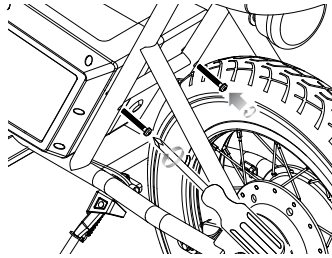

**17** Using a Phillips screwdriver replace the two (2) screws at the back of the battery box.

# REPAIR AND MAINTENANCE

## ❑ **Cleaning Your Rambler 16**

Wipe with a damp cloth to remove dirt and dust. Do not use industrial cleaners or solvents as they may damage the surfaces. Do not use alcohol, alcohol-based or ammonia-based cleaners as they may damage or dissolve the plastic components or soften the decals or decal adhesive.

## ❑ **Battery Care and Disposal**

Do not store in freezing or below freezing temperatures. To properly maintain your battery and ensure maximum battery life, carefully read the "Charging the Battery" section on page 5 of this owner's manual.



CONTAINS SEALED LEAD-ACID BATTERY. BATTERY MUST BE RECYCLED.

**Disposal:** Your Razor product uses sealed lead-acid battery which must be recycled or disposed of in an environmentally safe manner. Do not dispose of a lead-acid battery in a fire. The battery may explode or leak. Do not dispose of a lead-acid battery in your regular household trash. The incineration, land filling or mixing of sealed lead-acid batteries with household trash is prohibited by law in most areas. Return exhausted battery to a federal or state approved lead-acid battery recycler or a local seller of automotive batteries.

## ❑ **Charger**

The charger supplied with this product should be regularly examined for damage to the cord, plug, enclosure and other parts and in the event of such damage, the product must not be charged until it has been repaired or replaced.

Use **ONLY** with the recommended charger.

Not intended for use at elevations greater than 2000 m above sea level.

## ❑ **Wheels**

Wheels and drive system are subject to normal wear and tear. It is the responsibility of the user to periodically inspect wheels for excess wear and replace hub motor components as required.

**⚠ WARNING:** If a battery leak develops, avoid contact with the leaking acid and place the damaged battery in a plastic bag. Refer to the disposal instructions at left. If acid comes into contact with skin or eyes, flush with cool water for at least 15 minutes and contact a physician.

**⚠ WARNING:** Battery posts, terminals and related accessories contain lead and lead compounds. **Wash your hands after handling.**

# TROUBLESHOOTING GUIDE

\*Product(s) should be turned **OFF** and fully charged prior to doing any Troubleshooting.

**NOTE:** All troubleshooting steps should be performed by an adult only.

<b>Problem</b>	<b>Possible Cause</b>	<b>Solution</b>
Does not work out of the box	Undercharged battery	Check lights on charger: Plugged into wall - Green Plugged into wall & unit - Red (charging) Plugged into wall & unit - Green (charging complete) No lights/Blinking lights - Replace charger
No longer works	No lights on charger	Check power to wall outlet and/or try a different outlet.
	Undercharged battery	Check lights on charger: Plugged into wall - Green Plugged into wall & unit - Red (charging) Plugged into wall & unit - Green (charging complete) No lights/Blinking lights - Replace charger
	Battery will not hold a charge	Replace battery.
Short run time/runs slow	Rider's weight	Do not exceed 220 lb (100 kg) maximum weight limit.
	Riding conditions	Use only on flat, dry surfaces. Avoid inclines and areas with heavy debris.
	Battery not fully charged	Charge product - refer to page 5 for charging information. Replace battery.
	Old/damaged battery	Charge battery at least once a month when not in use.

# RAMBLER 16 PARTS

Keep your Rambler 16 running for years with genuine Razor parts. (Specifications subject to change without notice.)

- |                                     |                                      |                                |                         |
|-------------------------------------|--------------------------------------|--------------------------------|-------------------------|
| 1. Handlebar Grips (Left/Right)     | 8. Front Light Mounting (Left/Right) | 15. Battery Mounting (Lower)   | 22. Kickstand           |
| 2. Single-Speed Twist-Grip Throttle | 9. Front Fork                        | 16. Controller                 | 23. Plastic Cover       |
| 3. Handlebar                        | 10. End Cap                          | 17. Battery (12V7AH)           | 24. Taillight           |
| 4. Brake Lever                      | 11. Headset (Upper/Lower)            | 18. Battery Cover (Left/Right) | 25. Taillight Supporter |
| 5. Handlebar Clamp                  | 12. Front Wheel                      | 19. Charger Port               | 26. Seat                |
| 6. Upper Crown                      | 13. Rear Wheel w/ Hub Motor Complete | 20. ON/OFF Switch              |                         |
| 7. Headlight                        | 14. Battery Mounting (Upper)         | 21. Footpegs (Left/Right)      |                         |

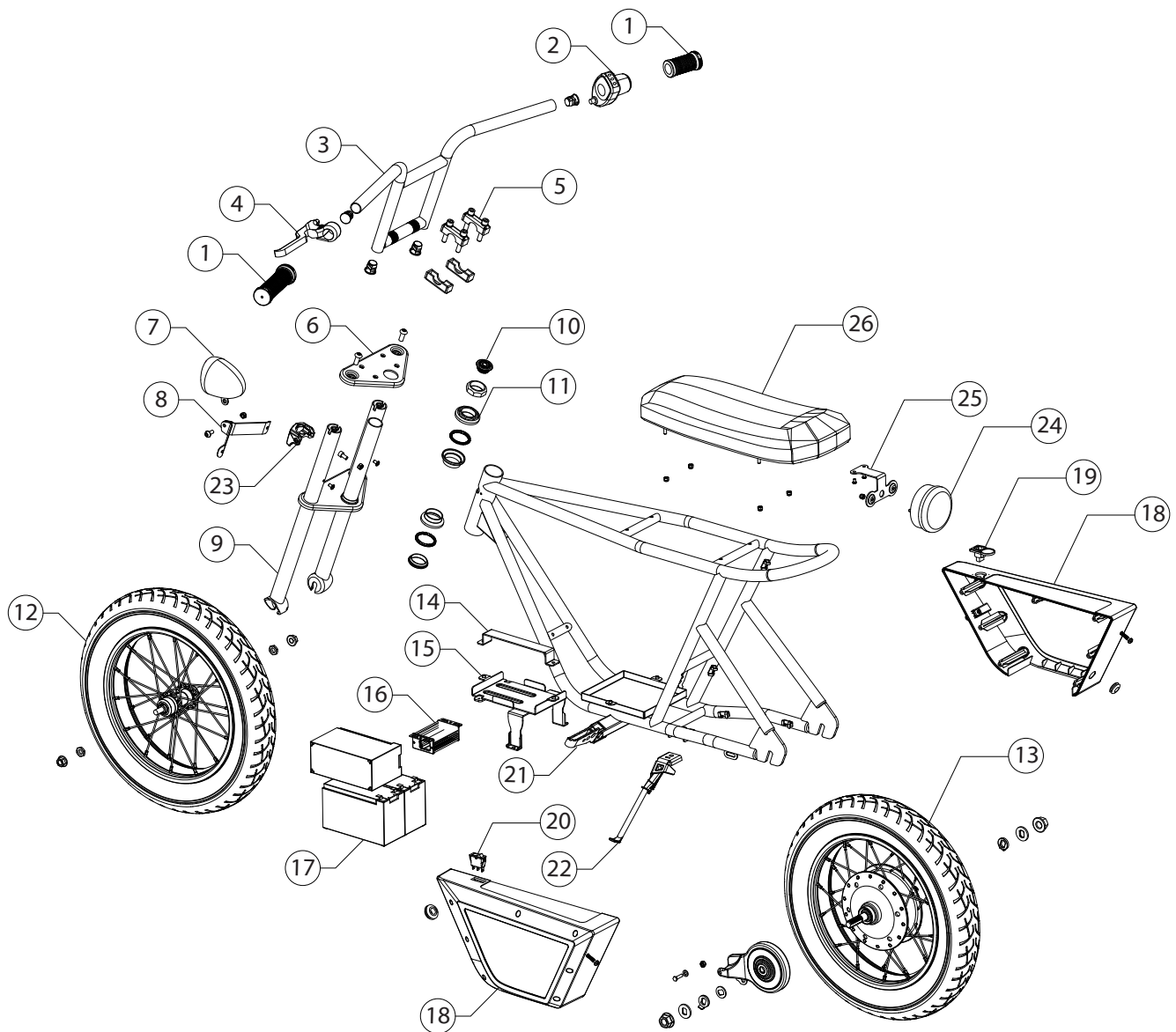

## FCC COMPLIANCE

This device complies with Part 15 of the FCC Rules. Operation is subject to the following two conditions: (1) This device may not cause harmful interference, and (2) this device must accept any interference received, including interference that may cause undesired operation.

Note: This equipment has been tested and found to comply with the limits for a Class B digital device, pursuant to part 15 of the FCC Rules. These limits are designed to provide reasonable protection against harmful interference in a residential installation. This equipment generates, uses and can radiate radio frequency energy and, if not installed and used in accordance with the instructions, may cause harmful interference to radio communications. However, there is no guarantee that interference will not occur in a particular installation. If this equipment does cause harmful interference to radio or television reception, which can be determined by turning the equipment off and on, the user is encouraged to try to correct the interference by one or more of the following measures:

- Reorient or relocate the receiving antenna.
- Increase the separation between the equipment and receiver.
- Connect the equipment into an outlet on a circuit different from that to which the receiver is connected.
- Consult the dealer or an experienced radio/TV technician for help.

**⚠ WARNING:** Changes or modifications to this unit not expressly approved by Razor USA, could void the user's authority to operate the equipment.

**NOTICE: INSURANCE**

**YOUR INSURANCE POLICIES MAY NOT PROVIDE COVERAGE FOR ACCIDENTS INVOLVING THE USE OF THIS SCOOTER/ELECTRIC RIDE-ON PRODUCT. TO DETERMINE IF COVERAGE IS PROVIDED, YOU SHOULD CONTACT YOUR INSURANCE COMPANY OR AGENT.**

**[www.razor.com/mx](http://www.razor.com/mx)**