



Razor®

DASH™

**FREEWHEELING &
ELECTRIC ASSIST
BALANCE BIKE**



OWNER'S MANUAL

**Read and understand this entire manual before
allowing child to use this product!**

**NOTE: Manual illustrations are for demonstration purposes only.
Illustrations may not reflect exact appearance of actual product.
Specifications subject to change without notice.**

www.razor.com/mx
Hecho en China

CONTENTS

Safety Warnings.....	1-2	Charging the Battery.....	6
Before You Begin.....	3	Usage.....	7
Assembly and Set-Up.....	4	Repair and Maintenance.....	8
Changing the Mode.....	5	Product Parts Breakdown.....	9
Changing the Speed Mode.....	5		

SAFETY WARNINGS

⚠ AN IMPORTANT MESSAGE TO PARENTS:

The Dash freewheeling & electric assist balance bike is intended to allow younger children to learn and to enjoy and develop their early experiences using ride-on toys. Studies suggest that children at age 3 have the coordination required to use a steering wheel or handlebar and can use a 2-wheeled product. The Dash is designed to help children learn and develop skills of balance and motion by starting in a non-powered mode and developing, with appropriate supervision and familiarity, the skills to move into low speed electric learning opportunities so that a child can develop riding skills that can be built upon in years to come.

Adult supervision is required as children learn and grow because children do not understand the risks of riding in areas with cars and are at a very high risk of falling off and injuring themselves as they first experience the fun – the needed skills and the risks – of riding something using first their own power, then electric power. Protecting children as they learn is an important part of the developmental process.

There are three modes available for riding this product: First, there is a non-powered, free-wheeling mode that is best for younger, novice riders, recommended for a minimum age of thirty (30) months; For riders who have mastered foot-powered riding, parents have the ability to adjust the product to allow either of the two electric-assisted modes – a lower speed mode (up to 3 mph, 5 km/h) and a slightly higher speed mode (up to 5 mph, 8 km/h). These adjustments require adult attention as described in the manual (see pages 5 & 7)

This manual contains important information. For your child's safety, it is your responsibility to review this information and make sure that you instruct your child to follow all warnings, cautions, instructions, and safety topics. Razor USA recommends that you periodically review and reinforce the information in this manual with younger riders, and that you inspect and maintain your child's product to ensure their safety.

WARNING: PARENTAL AND ADULT RESPONSIBILITY AND SUPERVISION IS NECESSARY: Riding a Dash freewheeling & electric assist balance bike does present potential risks and caution is required. Because products, like the Dash, can and do present potential hazards plainly associated with their use, it is well recognized THE NEED FOR EXERCISE OF PARENTAL RESPONSIBILITY IN SELECTING RIDING PRODUCTS APPROPRIATE TO THE AGE OF A CHILD, OR PARENTAL SUPERVISION IN SITUATIONS IN WHICH CHILDREN OF VARIOUS AGES MAY HAVE ACCESS TO THE SAME RIDING PRODUCTS, IS IMPORTANT.

Not every product is appropriate for every age or size of child, and different age recommendations are found within this category of product which are intended to reflect the nature of the hazards and the expected mental or physical ability, or both, of a child to cope with the hazards.

Keep this product away from very small children and remember that it is intended for use only by children who are, at a minimum, completely comfortable and competent while operating the Dash.

Children with any mental or physical conditions that may make them susceptible to injury, impair their physical dexterity or mental capabilities to recognize, understand, and follow safety instructions and to be able to understand the hazards inherent in Dash use, should not use or be permitted to use products inappropriate for their abilities.

WARNING: Riding 2-wheeled products, such as this balance bike can be a hazardous activity. Certain conditions may cause the equipment to fail without fault of the manufacturer. Such products can and are intended to move, and it is therefore possible to lose control, fall off and/or get into dangerous situations that no amount of care, instruction or expertise can eliminate. If such things occur, you can be seriously injured or die, even when using safety equipment and other precautions. LIKE ANY OTHER MOVING PRODUCT, USING THIS PRODUCT CAN BE A DANGEROUS ACTIVITY AND MAY RESULT IN INJURY OR DEATH EVEN WHEN USED WITH PROPER SAFETY PRECAUTIONS. RIDE AT YOUR OWN RISK AND USE COMMON SENSE.

This manual contains many warnings and cautions concerning the consequences of failing to maintain, inspect or properly use your Razor product. Because any incident can result in serious injury or even death, we do not repeat the warning of potential serious injury or death each time such a possibility is mentioned.

- This product does not have a brake.
- Do not allow children under age thirty (30) months to use this product. Direct adult supervision is required at all times. The recommended rider age of thirty (30) months and older for Dash is only an estimate, and can be affected by the rider's size, weight, or skills. Any rider unable to fit comfortably on the Dash should not attempt to ride it.
- Manufacturer's suggested minimum rider age is thirty (30) months in the Freewheeling (non-powered) Mode and three (3) years in the Electric Assist Mode. The default setting is Freewheeling Mode.
- Always pay attention to where your child is going; do not allow use of the throttle to distract rider from safe riding practices.
- Safety equipment, such as helmet, knee pads and elbow pads are recommended. Always ensure your child is wearing a helmet when riding this product and keep the chinstrap securely buckled.
- Always wear closed toe shoes.
- Ride on smooth, paved surfaces without loose debris, such as rocks or gravel, and away from motor vehicles.
- Avoid sharp bumps, drainage grates, and sudden surface changes as this product may suddenly stop.
- Avoid streets and surfaces with water, puddles, mud, ice, sand, gravel, leaves and other debris. Wet weather impairs traction, stopping, and visibility.
- Do not ride at night or when visibility is impaired.
- Avoid excessive speed associated with downhill rides.
- Obey all local traffic laws and regulations.
- Watch out for pedestrians.
- **DO NOT EXCEED 44 LB (20 KG) TOTAL WEIGHT ON THIS RAZOR PRODUCT.**
- **RIDER WEIGHT DOES NOT NECESSARILY MEAN A CHILD'S SIZE IS APPROPRIATE TO FIT OR MAINTAIN CONTROL OF THIS PRODUCT.**
- **A parent's decision to allow his or her child to ride this product should be based on the child's maturity, skill, and ability to follow rules.**

SAFETY WARNINGS

CHECK AND MAINTAIN PRODUCT CONDITIONS

The Dash should be maintained and repaired in accordance with the manufacturer's specifications, using only the manufacturer's authorized replacement parts, and should not be modified from the manufacturer's original design and configuration.

ACCEPTABLE RIDING PRACTICES AND CONDITIONS

Direct parental supervision is required at all times. Always check and obey any local laws or regulations which may affect the locations where the Dash may be used on public property. This product is meant to be used only in controlled environments, free of potential traffic hazards and not on public streets. Do not allow your child to ride this product in any areas where pedestrian or vehicle traffic is present. Never use near streets, steps, sloped driveways, hills, roadways, alleys or swimming pool areas. Never allow your child to use headphones, a cell phone or text when riding. Never allow your child to hitch a ride with a vehicle.

The Dash is intended for use on solid, flat, clean and dry surfaces, such as pavement or level ground, without loose debris, such as dirt, leaves, rocks or gravel.

Do not activate the electric mode unless child is on the Dash and in a safe, outdoor environment suitable for riding.

WARNING: PARENT CONTROLLED HIGH/LOW SPEED SWITCH: The Dash has a HIGH-LOW speed switch which can be manually set by an adult before children ride it. This switch allows parents to reduce the Dash speed for novice riders in the electric assist mode. See page 5. The default setting is LOW. The normal powered top speed of the Dash will be approximately 5 mph (8 km/h), which can be affected by conditions, such as rider weight, inclines, and battery charge level. Avoid excessive speeds that can be associated with downhill rides. Ride on level and flat ground only.

Ride defensively. Watch out for potential obstacles that could catch the wheel or cause the rider to swerve suddenly or lose control. Be careful to avoid pedestrians, skaters, skateboards, scooters, electric products, bikes, children or animals who may enter your path, and respect the rights and property of others.

Wet, slick, bumpy, uneven or rough surfaces may impair traction and contribute to possible accidents.

Child must maintain a hold on the handlebars at all times. Never carry passengers or allow more than one child at a time to ride this product.

Do not allow hands, feet, hair, body parts, clothing, or similar articles to come in contact with moving parts or wheels while the motor is running.

Do not ride your Dash in wet or icy weather and never immerse the Dash in water, as the electrical and drive components could be damaged by water or create other possibly unsafe conditions. Never risk damaging surfaces, such as carpet or flooring, by use of a Dash indoors.

PROPER RIDING ATTIRE

Always ensure child is wearing proper protective equipment, such as an approved safety helmet and keep chinstrap securely buckled. A helmet may be legally required by local law or regulation in your area. A long-sleeved shirt, long pants, and gloves are recommended. Always wear athletic shoes (lace-up shoes with rubber soles) and keep shoelaces tied and out of the way of the wheels and motor. Knee pads and elbow pads are recommended. A child should never ride barefooted or in sandals.

USING THE CHARGER

The charger supplied with the Dash should be regularly examined for damage to the cord, plug, enclosure, and other parts. In the event of such damage, the Dash must not be charged until the charger has been repaired or replaced.

Use only with the recommended charger.

Use caution when charging.

The charger is not a toy. Charger should be operated by an adult.

Do not operate charger near flammable materials.

Unplug charger and disconnect from Dash when not in use.

Always disconnect from the charger prior to wiping down and cleaning your Dash with damp cloth.

⚠ WARNING: ALWAYS INSPECT THIS PRODUCT PRIOR TO RIDING. Properly inspecting and maintaining this product can reduce the risk of injury. Always inspect this product before riding and regularly maintain it. Replace worn parts when they occur.

⚠ WARNING: CHECK LOCAL LAWS REGARDING USE OF THIS PRODUCT. Check local laws and regulations to see where and how you may use this product legally. In many states and local areas 2-wheeled product riders are required BY LAW to wear a helmet. Check local laws and regulations regarding laws governing helmet use and 2-wheeled product operation in your area.

FAILURE TO USE COMMON SENSE AND HEED THE WARNINGS INCREASES RISK OF SERIOUS INJURY. USE AT YOUR OWN RISK. USE WITH APPROPRIATE CAUTION AND SERIOUS ATTENTION TO SAFE OPERATION.

BEFORE YOU BEGIN

Adult assembly required. Remove contents from box. Inspect the contents for scratches in the paint and/or dents that may have occurred during shipping. Because this product was partially assembled and packed at the factory, there should not be any problems, even if the box has a few scars or dents.

MAKE SURE POWER SWITCH IS TURNED "OFF" BEFORE CONDUCTING ANY ASSEMBLY OR MAINTENANCE PROCEDURES.

Estimated Assembly and Set-Up Time

Razor recommends assembly by an adult or someone with experience in bicycle mechanics.

Allow up to 10 minutes for assembly, not including initial charge time.

Allow up to 12 hours for charge (see page 6 for charging information).

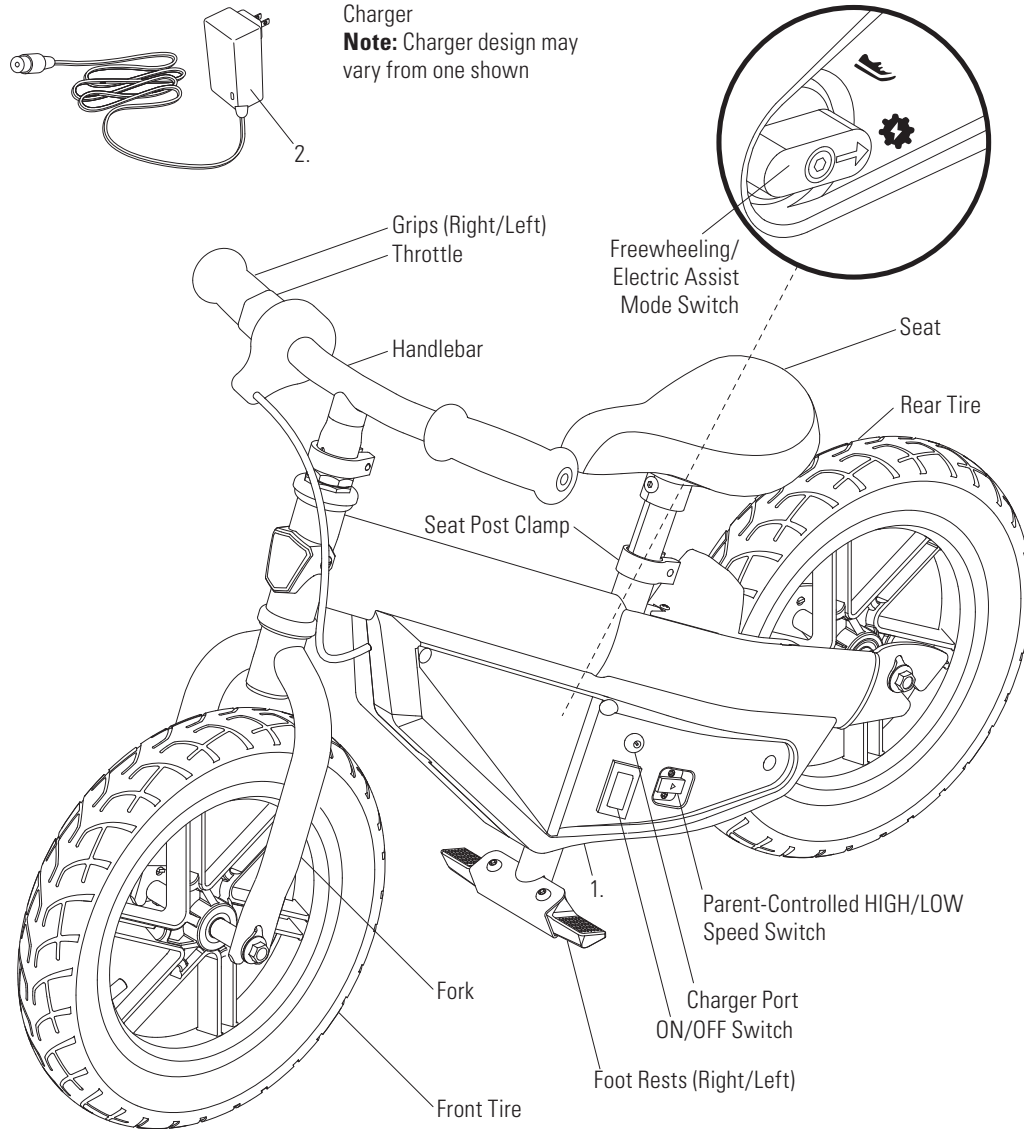

WARNING: DO NOT USE NON-RAZOR PRODUCTS WITH YOUR RAZOR BALANCE BIKE. Razor Balance Bikes have been built to certain Razor design specifications. The original equipment supplied at the time of sale was selected on the basis of its compatibility with the frame and all other parts.

Product ID Locations:

(See locations to the left)

1. Frame (underneath unit)
2. Charger
3. Box - side of UPC (not shown)

Required Tools

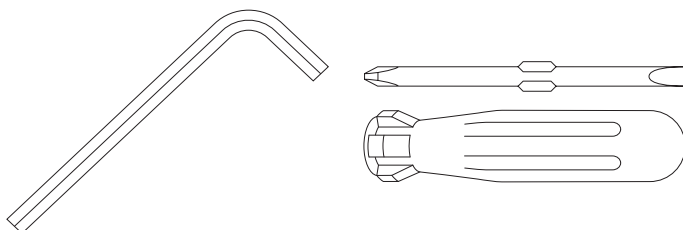

5 mm Allen Wrench
(included)

Phillips/Flathead Screwdriver
(included)

Plastic Bag Contents:

- Tools
- Owner's Manual

ASSEMBLY AND SETUP

□ Attaching the Handlebars

Required Tool: 5 mm Allen Wrench (included)

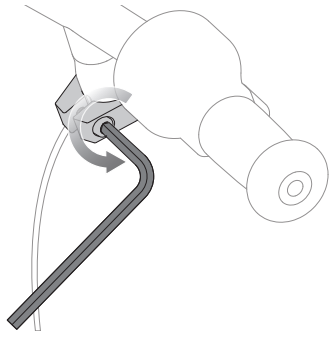

1 Loosen collar clamp bolt using a 5 mm Allen wrench.

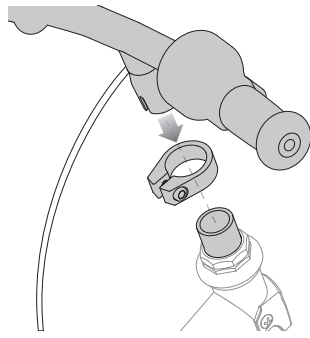

2 Align the handlebars, collar clamp and front fork as show in image above.

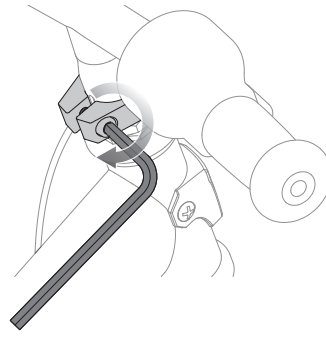

3 Tighten collar clamp bolt using a 5 mm Allen wrench. Tighten securely.

□ Attaching the Seat

Required Tool: 5 mm Allen Wrench (included)

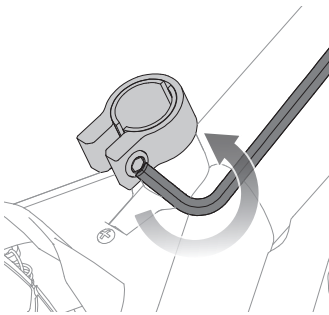

1 Loosen seat post clamp using a 5 mm Allen wrench.

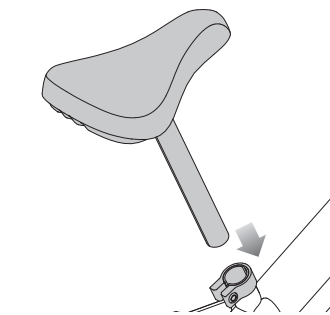

2 Align the seat, seat post clamp and seat post as show in image above.

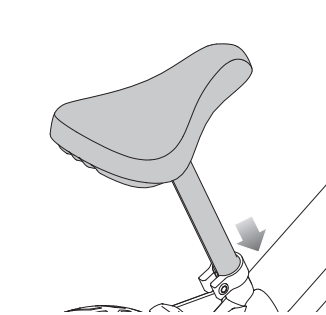

3 Install seat into seat post and adjust height.

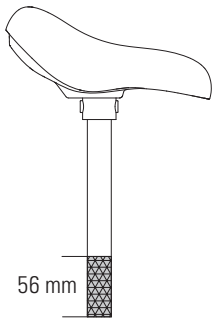

Note: The minimum insertion depth of the seat is 56 mm.

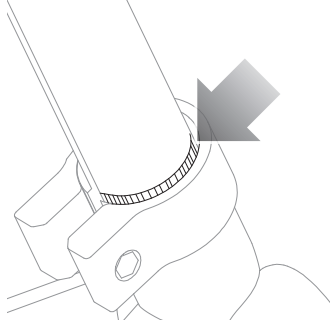

Note: The assembly and adjustment should not pass the safety line.

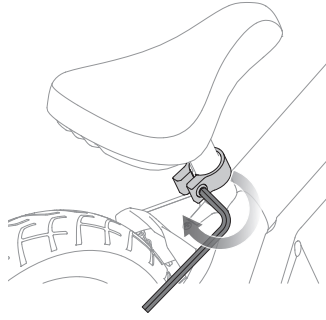

4 Tighten seat post clamp bolt using a 5 mm Allen wrench. Tighten securely.

□ Inflating the Tires

The tires are inflated when shipped, but they invariably may lose some pressure between the point of manufacturing and your purchase. **Always inflate tires to the correct PSI before first time use.**

Lower air pressure can result in a shorter ride time. Periodically check tires. Reinflate when needed.

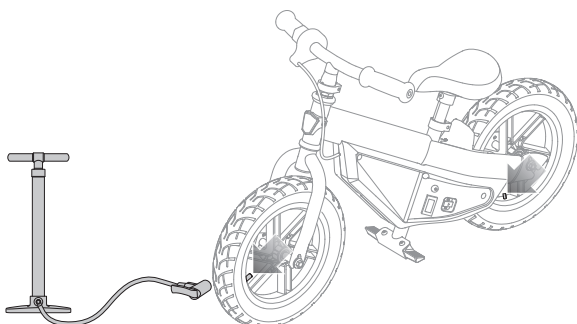

1 Using a bicycle style tire pump equipped for a Schrader-type valve, inflate the tires to the correct PSI indicated on the sidewall of the tires.

Note: Maintaining proper tire pressure is important to the Electric Assist drive system. always keep your tires inflated to the proper pressure for maximum performance.

⚠ WARNING: Do not attempt to thread the stem into the front fork thread.

Note: Make sure any cables/wires are out of the way before inserting the stem into the fork.

⚠ WARNING: Failure to properly tighten the collar clamp may allow the handlebars to dislodge while riding and may cause you to lose control and fall. When correctly tightened, the handlebars will not rotate out of alignment with the front wheel under normal circumstances.

Note: The cable and wire assembly from the handlebar must not wrap around the steering tube or handlebar. Sharp bends or twisting of the throttle cable can cause the throttle to malfunction.

⚠ WARNING: Check handlebar grips regularly for wear or damage, as grips are designed to aid in gripping handlebars and to provide some protection against possible impact. Replace immediately if worn, torn, damaged or missing.

⚠ WARNING: Failure to properly install and tighten the seat may cause the rider to lose control and fall. If you do not understand these instructions, contact Razor customer care for assistance.

⚠ WARNING: Do not use the electric balance bike for the first time until you have inflated the tires to the correct PSI. Failure to do so may damage your electric balance bike.

⚠ WARNING: Do not overinflate, as this could damage the tires or wheels.

Note: The pressure air supplies found at gasoline stations are designed to inflate high-volume automobile tires. If you decide to use such an air supply to inflate your electric balance bike tires, first make sure the pressure gauge is working, then use very short bursts to inflate to the correct PSI. If you inadvertently overinflate the tires, release the excess pressure immediately.

CHANGING THE MODE

□ Changing Between Freewheeling and Electric Assist Modes

Note: The Dash is set to the Freewheeling mode and on the LOW speed (Electric Assist) mode setting at the factory.

The Electric Assist (MOTOR) setting allows for speeds up to 5 mph (8 km/h).

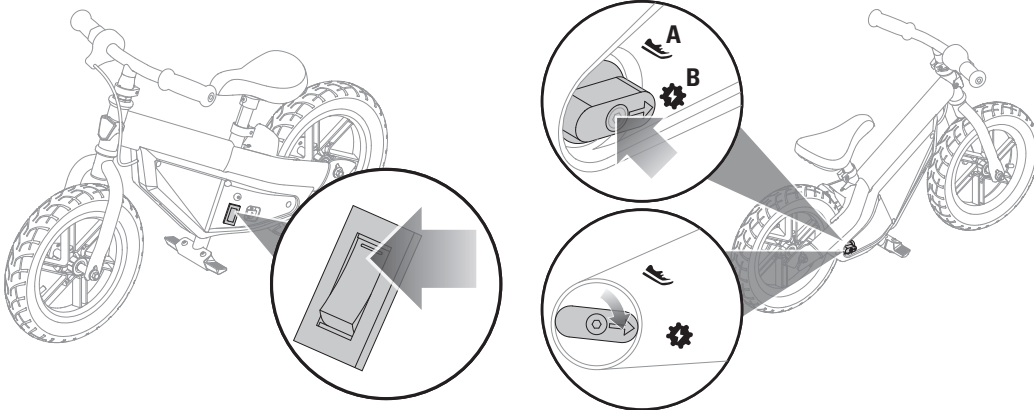

1 Start with the power switched to the OFF position.

2 To change between modes, push the selection knob in and turn towards the desired mode.

Note: If Electric Assist mode is selected, the throttle will be active when the power is switched on.

⚠ WARNING: Parents need to make any decisions to change between Freewheeling (non-powered), Electric Assist and Speed Modes, based upon the parents' assessment of their child's development of balance, skills and maturity used in riding 2-wheeled products.

Note: Manufacturer's suggested minimum rider age is thirty (30) months in the Freewheeling (non-powered) Mode and three (3) in the Electric Assist Mode.

Note:

= Freewheeling Mode (A)

= Electric Assist Mode (B)

CHANGING THE SPEED MODE

□ Parent-Controlled HIGH/LOW Speed Switch

Required Tool: Phillips Screwdriver (included)

Note: The Dash is set on the LOW speed setting at the factory.

The HIGH setting allows for speeds up to 5 mph (8 km/h).

The LOW setting allows for speeds up to 3 mph (5 km/h).

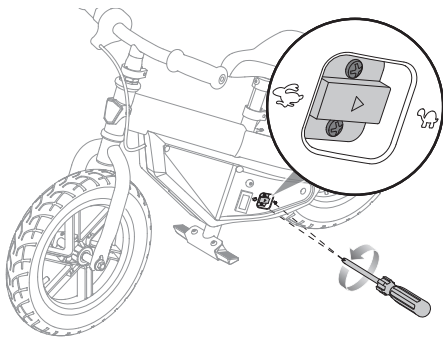

1 Using a Phillips screwdriver, remove the two (2) screws from the speed switch cover and set aside.

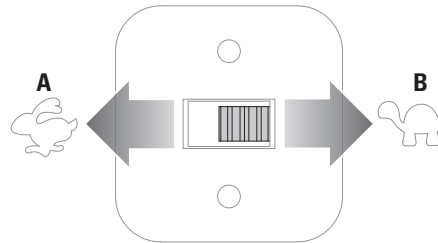

2 Move the switch to the left for HIGH speed mode (A) or to the right for LOW speed mode (B).

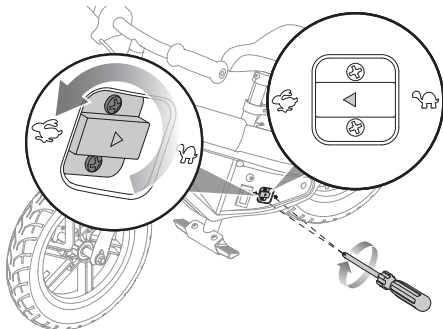

3 Rotate the cover so the arrow is facing the direction of the selected speed setting and replace the two (2) screws with a Phillips screwdriver.

Note: The red speed switch is located next to the power switch.

CHARGING THE BATTERY

Your Dash may not have a fully charged battery; therefore you must charge the battery prior to use. Be sure to charge the battery in a clean, dry location away from direct sunlight, flames or sparks.

- Use ONLY the battery supplied with unit at the time of purchase.
- Initial charge time: 12 hours.
- Recharge time: up to 4 hours, even if the light turns green. Recommended maximum charging time is 24 hours.
- Always charge the battery immediately after riding.
- Fully charge battery before storing for extended periods of time.
- Unplug charger from the wall outlet when not in use.
- Failure to recharge battery periodically may result in a battery that will not accept a charge.
- Make sure the power button is turned OFF when product is not in use. If the power button is left on for an extended period of time, the battery may reach a stage at which it will no longer hold a charge.
- To ensure long battery life, never store the product in freezing or below freezing temperatures! Freezing will permanently damage the battery.
- Electric Assist Run time: Up to 30 minutes of continuous ride time. Run time may vary depending on riding conditions, rider weight, climate, and/or proper maintenance. **Note:** This product can be used in Freewheeling mode when battery charge is depleted.
- Constant starting and stopping may shorten ride time.
- Battery life can vary depending on proper maintenance and usage of the product.
- Do not charge at or below 32°F (0°C).

⚠ WARNING: Use ONLY with the recommended charger. Battery is only to be charged under adult supervision. The charger is not a toy. Always disconnect the charger before wiping down and/or cleaning the Dash with a damp cloth.

The charger supplied with the Dash should be regularly examined for damage to the cord, plug, enclosure and other parts. In the event of such damage, the Dash must not be charged until it has been repaired or replaced.

Chargers have built-in overcharge protection to prevent battery from being overcharged.

Note: If the charger gets warm during regular use, this is a normal response and is no cause for concern. If your charger does not get warm during use, it does not mean that it is not working properly.

Wall outlet - Green (stand by)
Wall outlet and unit - Red (charging)
Wall outlet and unit - Green (charged)

Note: Continue charging unit even if light turns green prior to 4 hours.

⚠ WARNING: Battery charge can deplete over time. Periodically recharge battery when not in use.

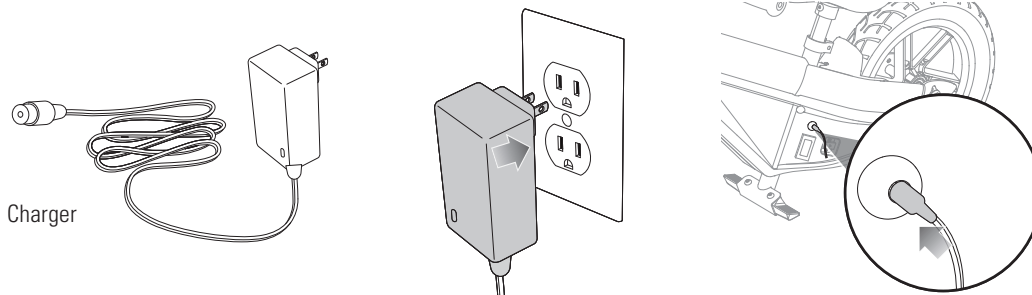

Charger
(Note: Charger design may vary from one shown)

1 Plug the charger plug into wall outlet. The light on the charger should be green.

Note: If green light (LED) does not turn on, try a different outlet.

2 Note: Make sure power button is in the **OFF** position. Plug the charger into the charger port. The light on the charger should turn red during charging. The light will turn green again when charging is complete.

Model	Voltage (Nominal) Vdc	Capacity (Nominal) Ah	Charge Temperature Range	Operating Temperature Range
Dash	12V	2.3 Ah	-10° to 50°C 14° to 122°F	-10° to 50°C 14° to 122°F

USAGE

Parent Guide

□ How to Ride

Today's kids have an advantage. Product testing shows a little electric assistance reduces the time it takes to learn the basics. With Razor's Dash electric assist balance bike, your kids will have an improved learning experience!

This Parent Guide section is designed to walk you through the steps that will help get your kids balanced and moving for their bike riding adventures.

□ Step 1. Freewheeling Mode

This is the traditional balance bike mode whereby kids propel themselves with their feet while steering, practicing, and learning the basics of balancing and moving. Kids will start to feel the balance point while propelling themselves at their own pace.

Lets Go!

With their hands on the handlebars and their feet on the ground, your child can start manually with the power OFF. A rider must be tall enough to walk the Dash while sitting comfortably in the seat, putting both feet flat on the ground. The rider first walks the Dash while standing over the seat, then while sitting in the seat. You can support your child by holding the handle under the back of the seat if needed, but remember, give your child the opportunity to get started on their own. The rider stops the Dash by placing both feet on the ground.

□ Step 2. Low Speed Electric Assist UP TO 3 MPH (5 KM/H)

Power Up...

Now that your child is familiar with moving and steering, it's time to add a little help. This low-speed (up to 3 mph (5 km/h)) electric assist mode will get them used to a steady pace and forward movement while they perfect their balance and steering skills. With the foot pegs still folded up and out of the way, set speed to LOW, engage the electric assist drive system and switch the power ON.

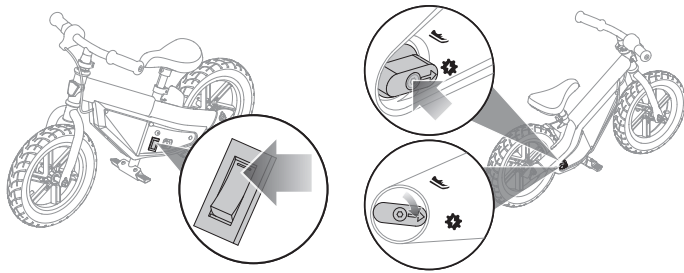

Kids should still use their feet as outriggers for balance but now they can twist the throttle to add some "assistance". LOW speed is walking speed for parents to accompany your child while they are first experiencing electric assist. In this case, the rider stops the Dash by releasing the throttle and placing both feet on the ground.



□ Step 3. High Speed Electric Assist UP TO 5 MPH (8 KM/H)

Launch!

At this point, your child is confident and having fun. Switch the speed to high-speed mode (up to 5 mph (8 km/h)) and fold down the foot pegs. Kids will get used to having their feet off the ground while remaining balanced in preparation for using pedals. The increased speed combined with all their other skills will help make bike riding intuitive for them, bringing them one step closer to riding a real pedal bike!

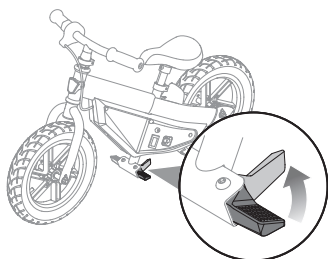

Note: Manufacturer's suggested minimum rider age is thirty (30) months in the Freewheeling (non-powered) Mode and three (3) in the Electric Assist Mode. The default setting is Freewheeling Mode.

Note: Freewheeling mode doesn't use any electric power, keep the power switch in the OFF position.

Note: Please see page 5 of this manual for instructions on how to switch between freewheeling, electric assist, and speed settings.

⚠ WARNING: Supervising adult should help child to sit on the Dash before adult turning power switch to ON.

Note: Power switch should be turned OFF before child sits on or exits Dash to avoid accidentally twisting active accelerator throttle, which could cause loss of balance.

Note: Please see page 5 of this manual for instructions on how to switch between electric assist speed settings.

REPAIR AND MAINTENANCE

Turn power switch "OFF" before beginning repair or maintenance:

- Read the instructions
- Remove charger plug
- Turn the power switch off
- Secure the unit under repair
- Exercise caution around exposed parts
- Contact Razor customer service if unsure about any repair or maintenance

❑ Removing the Tires

Required Tools: 12 mm and 14 mm wrench (not included)

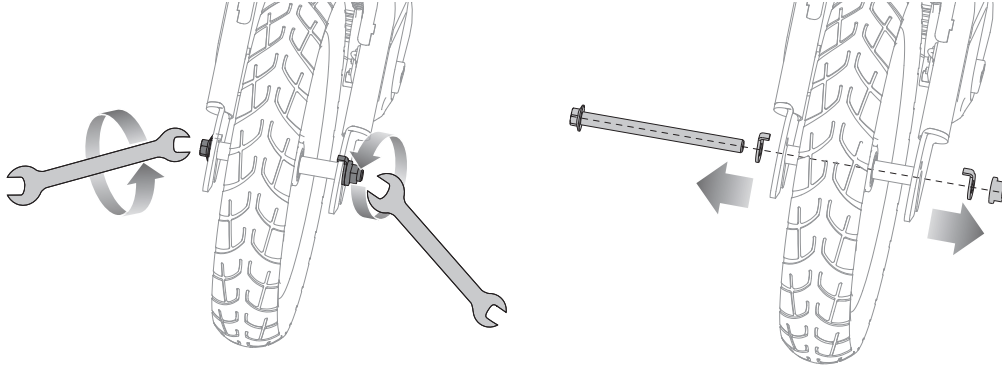

1 Using a 12 mm and 14 mm wrench, loosen the axle bolt. Remove wheel and install replacement wheel. (Note the sequence of the hardware)

❑ Cleaning Your Product

Wipe with a damp cloth to remove dirt and dust. Do not use industrial cleaners or solvents as they may damage the surfaces. Do not use alcohol, alcohol-based or ammonia-based cleaners as they may damage or dissolve the plastic components or soften the decals or decal adhesive.

❑ Battery Care and Disposal

Do not store in freezing or below freezing temperatures. To properly maintain your battery and ensure maximum battery life, carefully read the "Charging the Battery" section on page 6 of this owner's manual.



CONTAINS SEALED LEAD-ACID BATTERY. BATTERY MUST BE RECYCLED.

Disposal: Your electric scooter uses a sealed lead-acid battery which must be recycled or disposed of in an environmentally safe manner. Do not dispose of a lead-acid battery in a fire; the battery may explode or leak. Do not dispose of a lead-acid battery in your regular household trash. The incineration, land filling or mixing of sealed lead-acid batteries with household trash is prohibited by law in most areas. Return exhausted batteries to a federal or state approved lead-acid battery recycler or a local seller of automotive batteries. If you live in Florida or Minnesota, it is prohibited by law to throw away lead-acid batteries in the municipal waste stream.

❑ Charger

The charger supplied with the electric scooter should be regularly examined for damage to the cord, plug, enclosure and other parts and in the event of such damage, the product must not be charged until it has been repaired or replaced.

Use **ONLY** with the recommended charger.

❑ Wheels

Wheels and drive system are subject to normal wear and tear. It is the responsibility of the user to periodically inspect wheels for excess wear and replace drive train components as required.

⚠ WARNING: If a battery leak develops, avoid contact with the leaking acid and place the damaged battery in a plastic bag. Refer to the disposal instructions at left. If acid comes into contact with skin or eyes, flush with cool water for at least 15 minutes and contact a physician.

⚠ WARNING: Battery posts, terminals and related accessories contain lead and lead compounds. **Wash your hands after handling.**

DASH PARTS

Keep your balance bike running for years with genuine Razor parts. (Specifications subject to change without notice.)

- | | | | |
|-----------------------------------|-------------------------|---|--------------------------------|
| 1. Handlebar Grips (Right & Left) | 7. Rear Wheel | 12. Footpeg (Left and Right) | 17. On/Off Switch |
| 2. Twist Grip Throttle | 8. Rear Fender | 13. Battery (12V/2.3aH) | 18. Charger Port |
| 3. Handlebar | 9. Microswitch | 14. Control Module | 19. Battery Cover (Left/Right) |
| 4. Seat | 9-1 Microswitch Sleeve | 15. Front Fork | 20. Headset (Upper/Lower) |
| 5. Front Wheel | 10. Switch | 16. Electric Assist Speed Switch | 21. Collar Clamp |
| 6. Tension Spring | 10-1 Compression Spring | 16-1 Electric Assist Speed Switch Cover | 22. Seat Clamp |
| | 11. Motor (12V) | | |

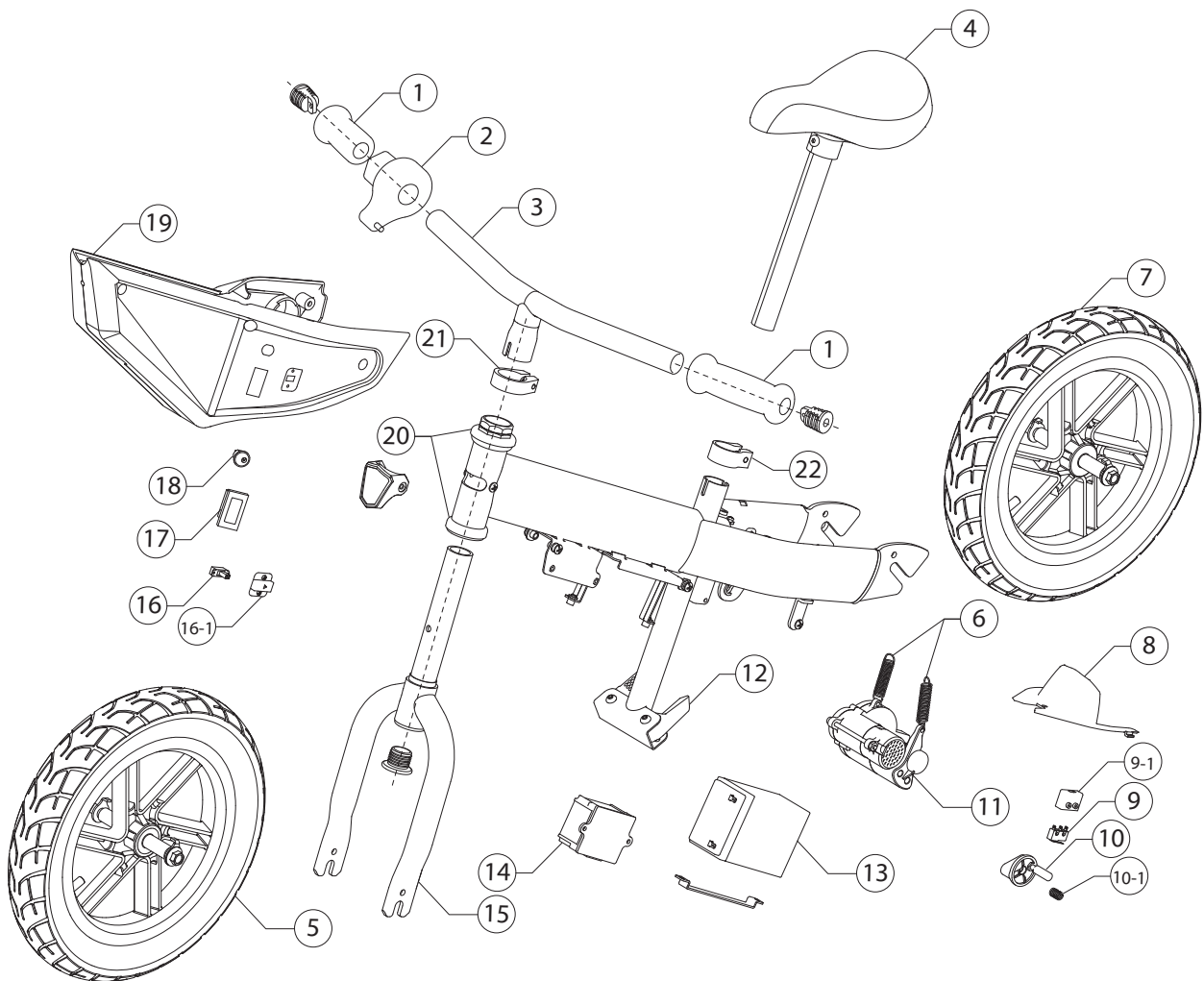

NOTICE: INSURANCE

YOUR INSURANCE POLICIES MAY NOT PROVIDE COVERAGE FOR ACCIDENTS INVOLVING THE USE OF THIS SCOOTER/ELECTRIC RIDE-ON PRODUCT. TO DETERMINE IF COVERAGE IS PROVIDED, YOU SHOULD CONTACT YOUR INSURANCE COMPANY OR AGENT.

FCC COMPLIANCE

This device complies with Part 15 of the FCC Rules. Operation is subject to the following two conditions: (1) This device may not cause harmful interference, and (2) this device must accept any interference received, including interference that may cause undesired operation.

Note: This equipment has been tested and found to comply with the limits for a Class B digital device, pursuant to part 15 of the FCC Rules. These limits are designed to provide reasonable protection against harmful interference in a residential installation. This equipment generates, uses and can radiate radio frequency energy and, if not installed and used in accordance with the instructions, may cause harmful interference to radio communications. However, there is no guarantee that interference will not occur in a particular installation. If this equipment does cause harmful interference to radio or television reception, which can be determined by turning the equipment off and on, the user is encouraged to try to correct the interference by one or more of the following measures:

- Reorient or relocate the receiving antenna.
- Increase the separation between the equipment and receiver.
- Connect the equipment into an outlet on a circuit different from that to which the receiver is connected.
- Consult the dealer or an experienced radio/TV technician for help.

⚠ WARNING: Changes or modifications to this product not expressly approved by Razor USA LLC, could void the user's authority to operate the equipment.

For your records, save your original sales receipt with this manual and write the serial number below.

www.razor.com/mx