



**EN** Read and understand this guide before using product.

**ES** Es imprescindible leer y comprender esta guía antes de usar el producto.



## Flashback™ BMX-Style Kick Scooter



1-10



11-12

[www.razor.com/lat](http://www.razor.com/lat)  
Hecho en China



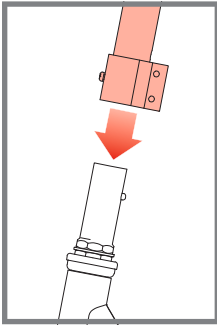
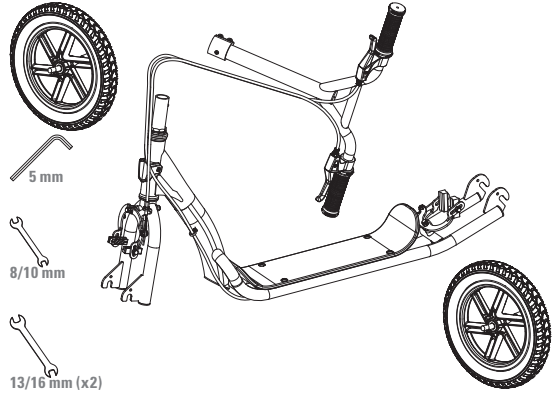

1

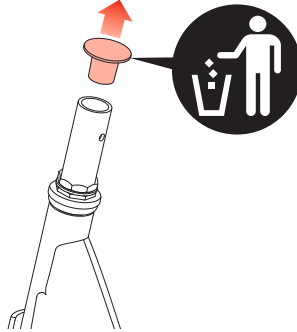

2

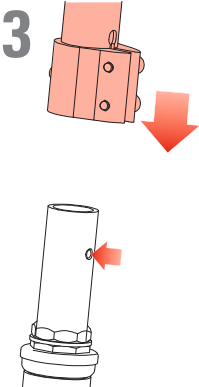
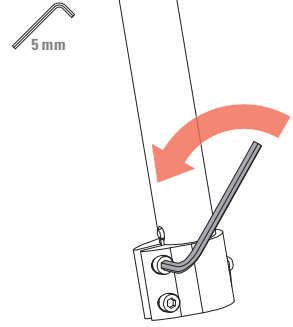

3

4

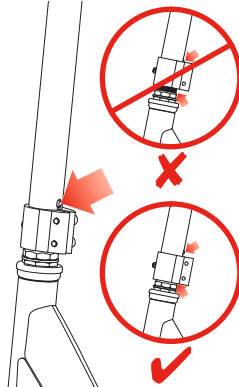

5

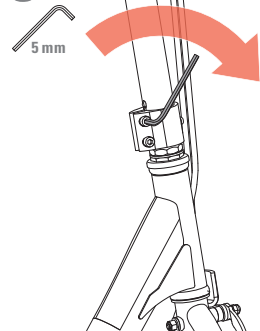



6

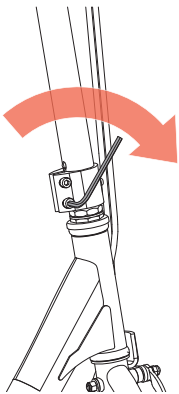

7

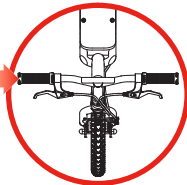
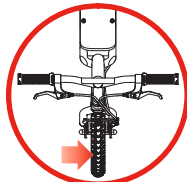

9



9



EN Attaching Front Wheel

ES Colocación de la rueda delantera

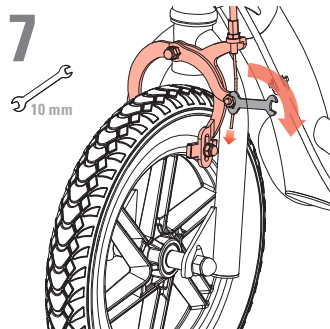
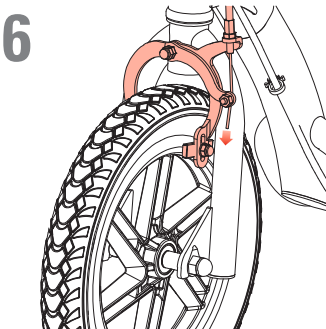
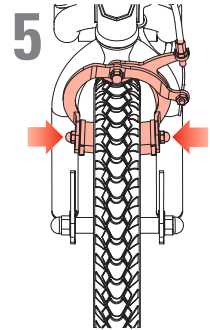
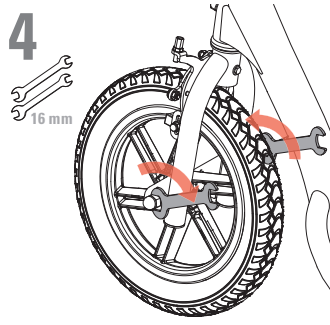
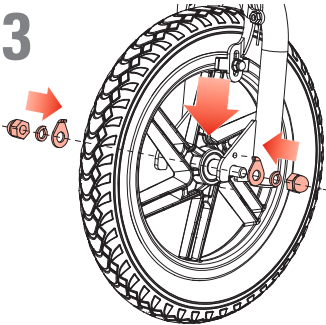
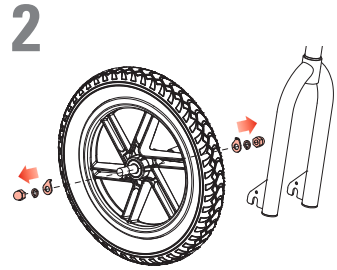
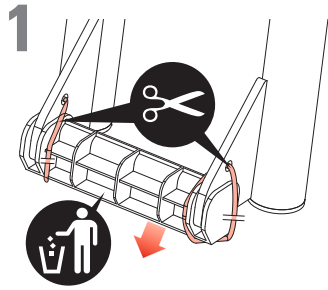
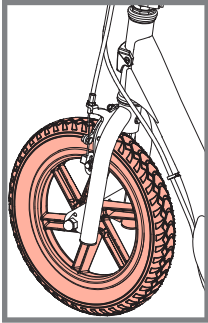



EN Attaching Rear Wheel  
ES Colocación de la rueda trasera

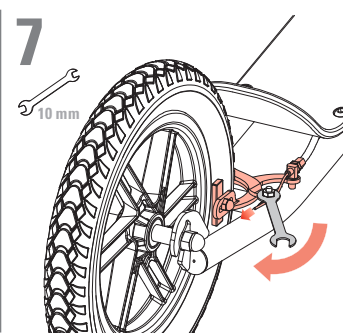
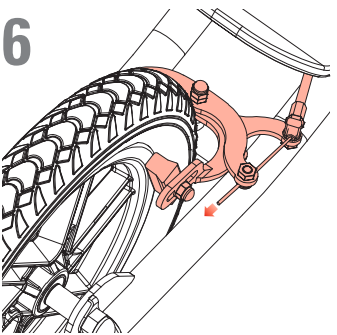
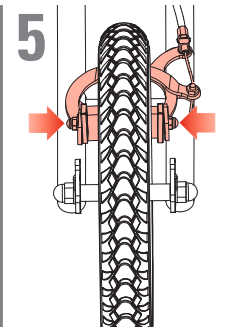
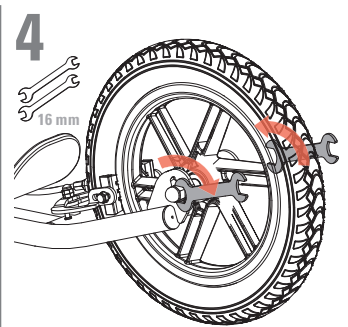
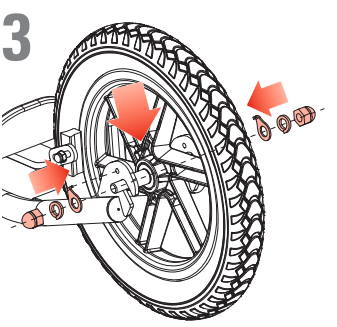
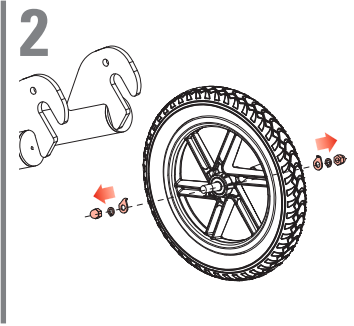
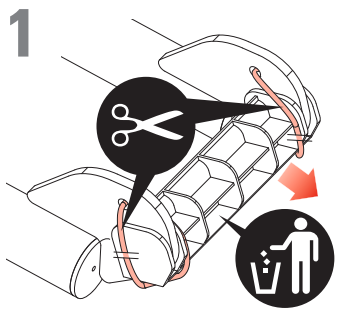
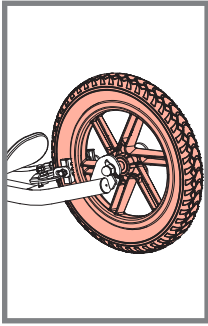

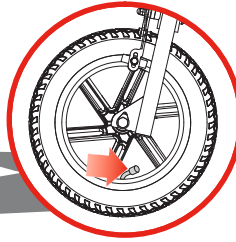
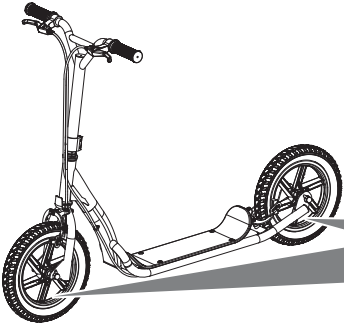

**35 PSI**  
**241 kPa**

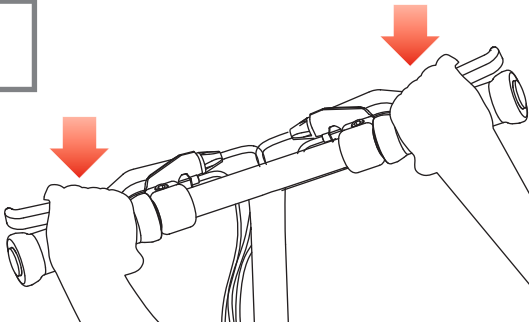
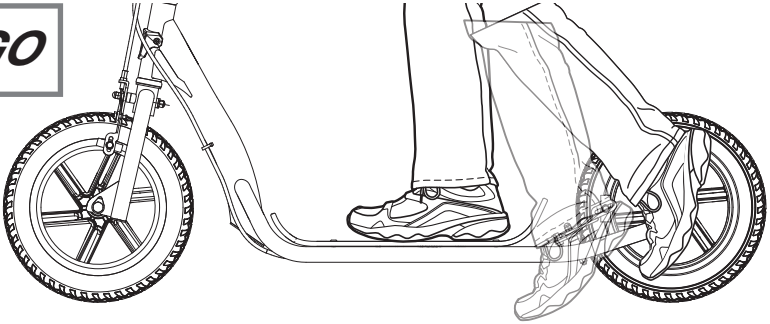
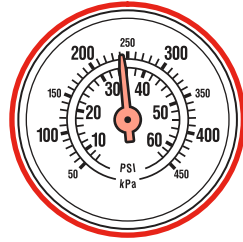

EN Adjusting brakes

ES Ajustando los frenos

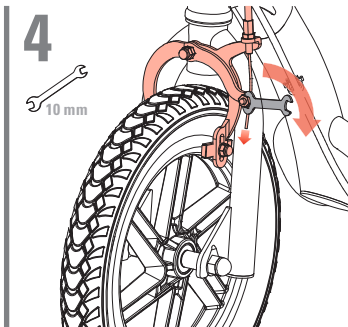
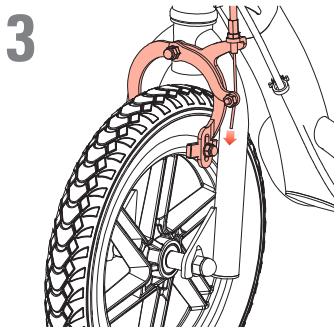
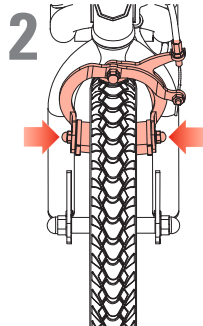
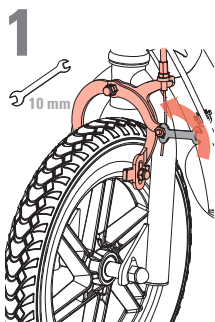
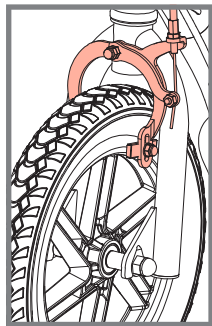



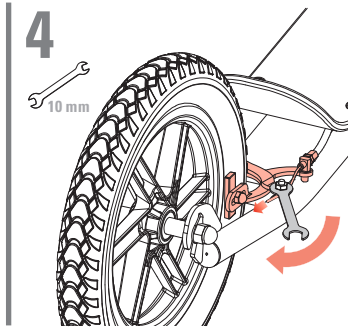
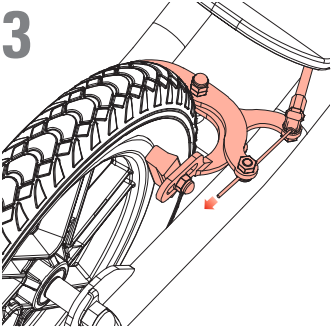
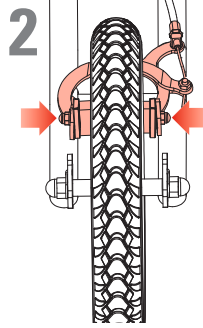
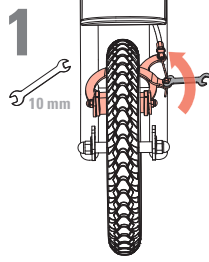
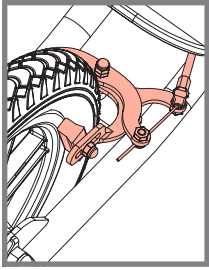



EN Front wheel replacement / Rear wheel replacement  
ES Cambio de la llanta delantera / Cambio de la llanta trasera

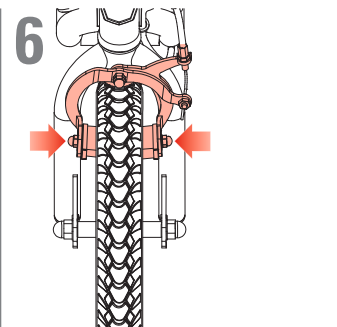
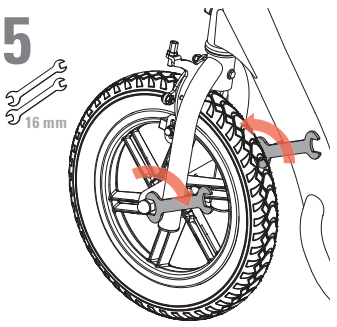
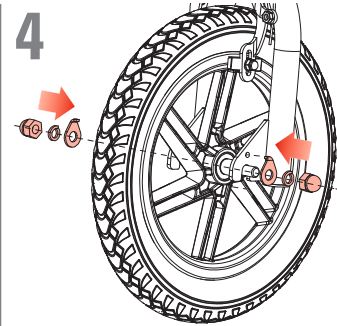
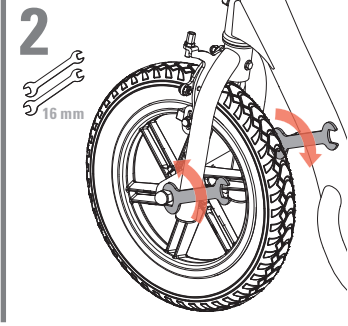
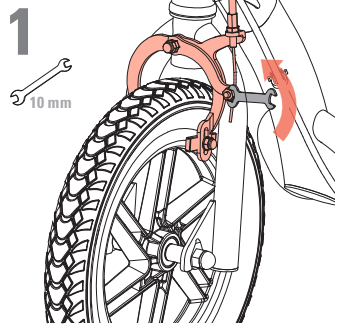
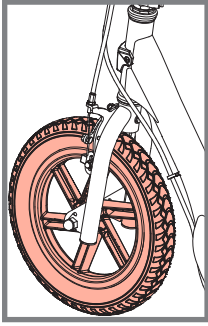

7

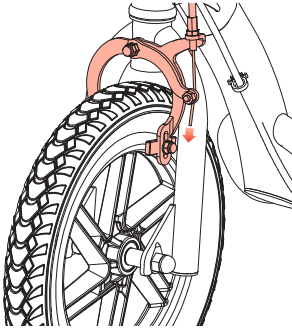

8

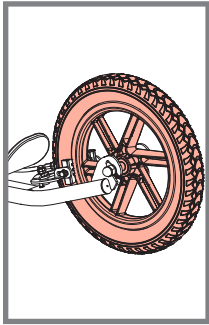
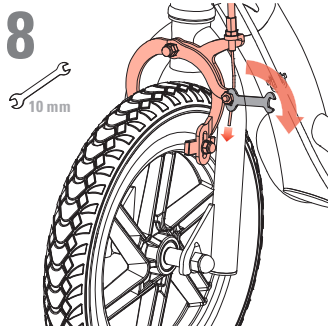

1

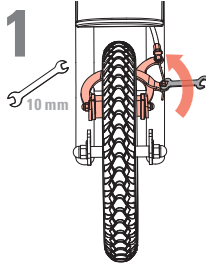

2

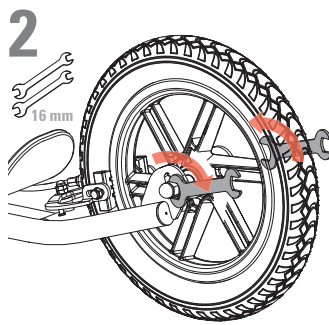

3

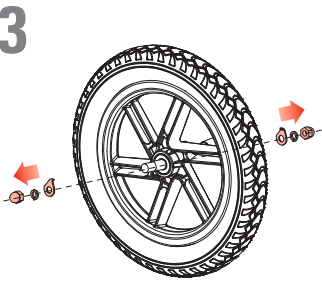

4

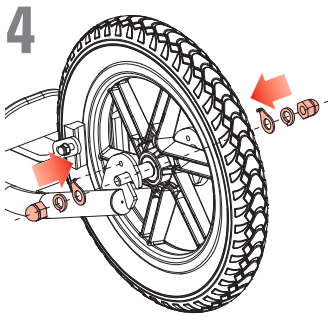



5

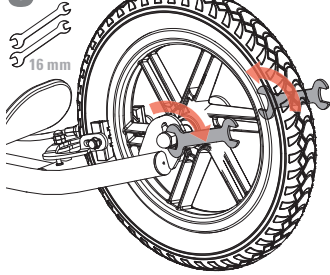

6

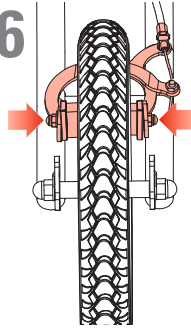

7

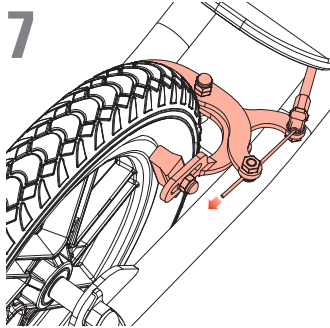

8

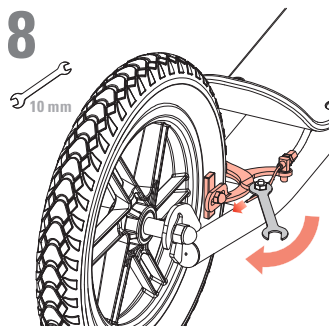



**WARNING. To avoid serious injury:**

- Adult supervision always recommended.
- Parents and carers should ensure that children are properly instructed in the use of this product.
- Hold handlebars at all times.
- Ride outdoors in places that allow you to improve your skills, and NEVER in traffic, on roads or near motor vehicles, where serious accidents can happen. Watch your surroundings for pedestrians, bike, skateboard, scooter and other riders. Use in areas free from hazards such as poles, hydrants, and parked cars.
- Wet weather impairs traction, braking and visibility.
- Never use near streets, swimming pools, hills, or steps. Use on smooth, dry, paved surfaces; avoid excessive speeds associated with downhill rides. Don't ride on loose debris (such as rocks, gravel or sand), or speed humps. Do not ride in the dark.
- Always wear shoes when using this product.
- Allow only one rider at a time on this product.
- Brakes will get hot from continuous use. Do not touch after braking.
- Like any other moving product, riding this product can be a dangerous activity and may result in injury even when used with proper safety precautions.
- While these are some of our strongest scooter products, that does not eliminate risks presented by scooter riding.

**Age and Weight Limits**

- Not for children under age 8.
- Maximum rider weight 100 kg.

**Protective Equipment**

- Always wear protective gear - helmet, elbow, knee and wrist guards (note parents should evaluate whether their child's use of wrist guards may impair their ability to hold handlebars).

**Failure to heed product warnings, or to exercise caution, increases risk of injury!****Where and How to Ride**

- The front brake is controlled by the brake lever on the left. The rear brake is controlled by the brake lever on the right. Each brake functions independently. For controlled stops apply one brake (by squeezing on the right or left brake lever) or apply both brakes (by squeezing both brake levers at the same time) for increased stopping power. Apply brake(s) until the product comes to a complete stop. Razor recommends that you practice applying the brakes at various speeds and in an open area free from obstructions before riding your scooter around others.
- Learn to fall (by rolling if possible) without the product.
- Learn with a friend or parent to help.
- Check local laws regarding where and how you may use your product.

**Maintenance**

- Properly inspecting and maintaining your scooter can reduce the risk of injury. Always inspect product before riding and regularly maintain it. Replace worn or damaged parts immediately.
- Check that the steering system is correctly adjusted and that all connection components are firmly secured and not broken.
- Check the brakes for proper function. When you squeeze the brake levers, the brakes should provide positive braking action.
- Under normal circumstances and conditions, the wheels and bearings are maintenance free.
- Always be sure to check tires for excessive wear or damage before riding.
- Do not exceed the tires PSI rating. Over inflation will cause a rupture.
- Regularly check that the various screwed parts are tight.
- No modifications can be made that can impair safety.
- Wipe with a damp cloth to remove dirt.
- If repairs are needed, bring product to a bicycle repair shop.
- Use only authorized Razor replacement parts.

**Failure to use common sense and heed the above warnings further increases risk of serious injury. Use at your own risk and with appropriate and serious attention to safe operation. Use caution.**

**ADVERTENCIA. Para evitar lesiones graves:**

- Se recomienda la supervisión permanente de un adulto.
- Los padres y personas al cuidado deben asegurarse de que los niños cuenten con la instrucción adecuada para usar este producto.
- Sujétese al manillar todo el tiempo.
- Patine en exteriores en lugares que le permitan mejorar sus habilidades y NUNCA en el tráfico o en carreteras o cerca de vehículos automotores, donde pueden causarse accidentes graves. Ponga atención a los peatones, ciclistas, usuarios de escúteres y de otros conductores. Use las áreas libres de peligros como postes, hidrantes y coches estacionados.
- El clima húmedo imposibilita la tracción, el frenado y la visibilidad.
- Nunca usar cerca de calles, piscinas, colinas o escalones. Utilícese en superficies planas, secas y pavimentadas; evite el exceso de velocidad cuando esté patinando cuesta abajo. No patine sobre superficies con escombros (como rocas, grava o arena) ni en montecillos. No patine en la oscuridad.
- Siempre lleve los zapatos puestos al usar este producto.
- Solamente puede subirse una persona a la vez en este producto.
- Los frenos se calientan con el uso continuo. No los toque después de frenar.
- Como todo otro objeto móvil, circular con este producto puede ser una actividad peligrosa y ocasionar lesiones, aun cuando se tomen las precauciones de seguridad correspondientes.
- Aunque éstos son algunos de nuestros productos más fuertes, eso no elimina los riesgos que se presentan al patinar.

**Límite de edad y peso**

- No está indicado para niños menores de 8 años.
- Peso máximo del patinador: 100 kg.

**Equipo de protección**

- Llevar siempre equipo de protección: casco, coderas, rodilleras y muñequeras (nota: los padres deben evaluar si el uso de muñequeras puede afectar la capacidad del niño para sostener el manillar).

**¡Hacer caso omiso de las advertencias sobre el producto o actuar sin la debida precaución aumentan el riesgo de sufrir lesiones!**
**Dónde y cómo conducir**

- El freno se calienta con el uso continuo. No lo toque después de frenar. El freno delantero está controlado por la palanca de freno de la izquierda. El freno trasero está controlado por la palanca de freno de la derecha. Cada freno funciona de forma independiente. Para paradas controladas, use solo un freno (apretando la palanca de freno derecha o izquierda) o ambos (apretando las dos palancas al mismo tiempo) para aumentar la energía de parada. Use el freno hasta que el producto se detenga completamente. Razor recomienda practicar el uso de los frenos a distintas velocidades, y en zonas abiertas y sin obstáculos, antes de conducir el patinete en otros lugares.
- Aprenda cómo caer (de ser posible rodando) sin el producto.
- Aprenda con un amigo o los padres, para que presten ayuda.
- Infórmese sobre las leyes locales, para saber dónde y cómo está permitido usar el producto.

**Mantenimiento**

- La inspección y el mantenimiento adecuado del patín pueden reducir el riesgo de lesiones. Inspeccionar siempre el producto antes de circular y efectuar un mantenimiento periódico. Sustituya partes dañadas y desgastadas inmediatamente.
- Verifique que el sistema de dirección esté correctamente ajustado y los componentes de conexión, firmemente sujetos y sin roturas.
- Compruebe el correcto funcionamiento de los frenos. Al apretar la palanca de los frenos, los frenos deben proporcionar una acción de frenado segura.
- En circunstancias y condiciones normales, las ruedas y los rodamientos no requieren mantenimiento.
- Asegúrese siempre de comprobar que los neumáticos no estén muy desgastados o dañados antes de ponerse a patinar.
- No supere la indicación PSI de los neumáticos. Si se inflan demasiado se pincharán.
- Verifique periódicamente que las distintas piezas atornilladas estén bien apretadas.
- No deben efectuarse modificaciones que pudieran afectar la seguridad.
- Limpie con un trapo húmedo para quitar la suciedad.
- Si fuera necesario reparar el producto, llevarlo a un taller de reparación de bicicletas.
- Utilice partes de repuestos Razor autorizados solamente.

**Si no se usa el sentido común y presta atención a las advertencias anteriores puede aumentar el riesgo de sufrir lesiones graves. Usese bajo su propio riesgo y con la atención correcta y seria para una operación segura. Tenga precaución.**





Copyright ©2003-2021 Razor USA LLC. All rights reserved. Razor® and the Razor logo design are among the registered trademarks of Razor USA LLC and/or its affiliated companies in the United States and/or select foreign countries. Flashback™ is a trademark of Razor USA LLC.



EN14619: 2019 (Class A)

**[www.razor.com/lat](http://www.razor.com/lat)**

25L\_211028